

Final Exam and End Material Test

Wednesday, Dec 13, 3:00-5:00

Test rooms:

Instructor	Sections	Room
• Dr. Musser	B, D, G, R	St. Pats Ballroom
• Dr. Hale	P	St. Pats Ballroom
• Dr. Wilemski	C, F	BCH 125
• Dr. Jentschura	A, Q	BCH 120
• Dr. Madison	H, L	EECH G-31
• Mr. Upshaw	E, J, M, N	G-3 Schrenk
• Dr. Hale	K	104 Physics
• Special Accommodations		Testing Center

(Contact me a.s.a.p. if you need accommodations different than for exam 3)

Announcements

Final exam day events (Wednesday, Dec. 13, 3:00pm to 5:00pm)

- 50-point multiple choice end-material test (covering material from chapters 33-36). (You get a free 8-point question!)
- 200 point comprehensive final exam, all problems (no multiple choice), about 50% emphasis on chapters 33-36

You may take neither, one, or both of these tests. Your choice.
No one admitted after 3:15pm!

You may spend your two hours however you see fit (all on end-material, all on final exam, some mix).

Announcements

Your end material test points have been set to 8 already.
(should be visible after next spreadsheet update Tuesday afternoon)

You do **not** need to take the test to receive these points.

Posted grade spreadsheets are active – play with the scores to see how many points you need for the next higher grade.

Zeros for boardwork can still lower your total points.

Grade cutoffs will **not be lowered** under any circumstances.

If any of your scores need to be fixed contact your recitation instructor NOW!

Announcements

PLC

PLC will run Monday afternoon and evening as usual

No PLC on Wednesday.

Teaching evaluations

<http://teacheval.mst.edu>

<http://teachevalm.mst.edu>

If you liked the class, please let us know! Constructive criticism is highly appreciated as well!

The links are available until Sunday before Finals Week.

LEAD Tutors/Peer Instructors Needed!

You can tutor or be a PLC peer instructor if you have at least a 3.6 GPA and get an "A" in the course you want to tutor.

Go to
<http://lead.mst.edu/>
to fill out the
[application form](#).

It looks good on your
resume, pays well,
and is fun!



Today's agenda:

Introduction to diffraction

Single-slit diffraction

Diffraction grating

Diffraction

Light is an electromagnetic wave, and like all waves, “bends” around obstacles.

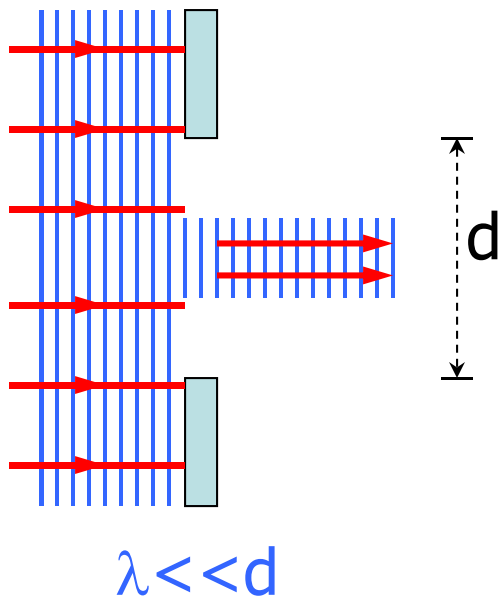

most noticeable when the dimension of the obstacle is close to the wavelength of the light

Diffraction pattern from a penny positioned halfway between a light source and a screen.

The shadow of the penny is the circular dark spot.

Notice the circular bright and dark fringes.

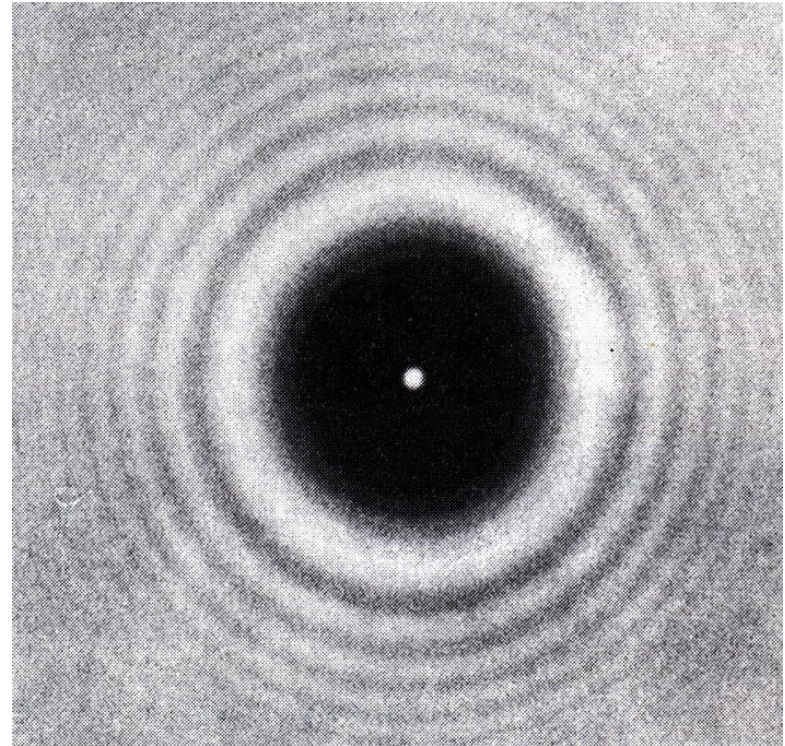

The central bright spot is a result of light "bending" around the edges of the penny and interfering constructively in the exact center of the shadow.

Good diffraction applets at <http://ngsir.netfirms.com/englishhtm/Diffraction.htm>
<http://micro.magnet.fsu.edu/primer/java/diffraction/basicdiffraction/>
<http://www.physics.uq.edu.au/people/mcintyre/applets/grating/grating.html>

Single Slit Diffraction

Recall: double-slit interference (lecture 26)

- slits were assumed infinitely thin (point sources)

Now: consider the effect of finite slit width

Single slit:

- each point in slit acts as source of light waves
- these different light waves interfere.

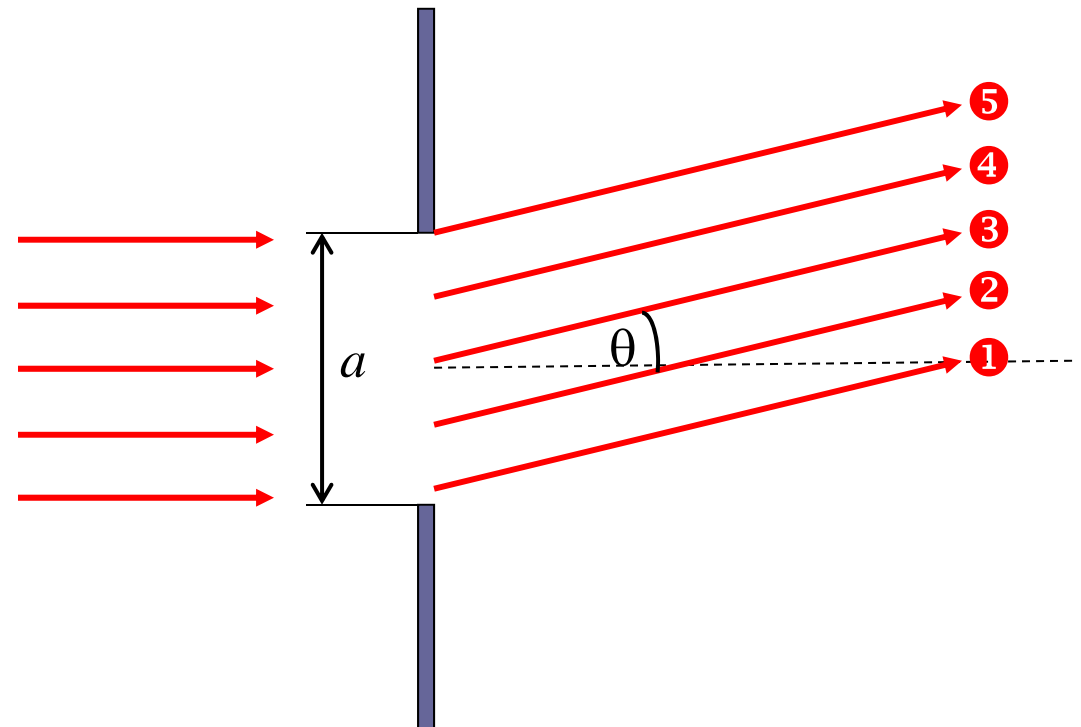

Imagine dividing the slit in half.

Wave ① travels farther*
than wave ③ by $(a/2)\sin\theta$.
Same for waves ② and ④.

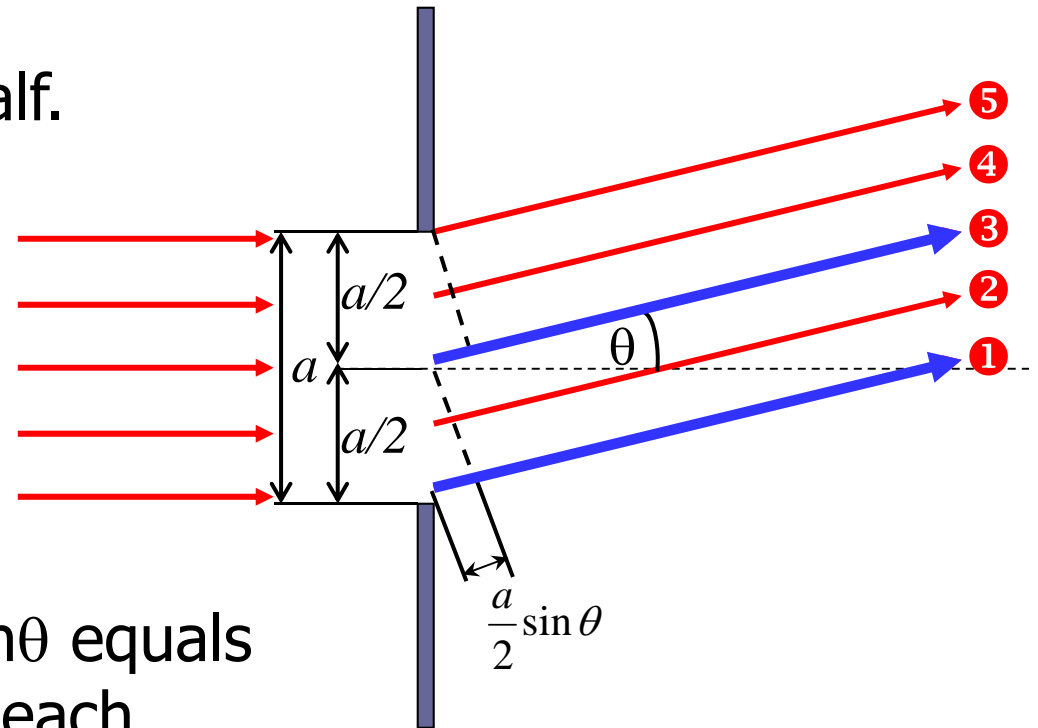

If the path difference $(a/2)\sin\theta$ equals $\lambda/2$, these wave pairs cancel each other \rightarrow destructive interference

Destructive interference: $\frac{a}{2}\sin\theta = \frac{\lambda}{2}$

*All rays from the slit are converging at a point P very far to the right and out of the picture.

Destructive
interference:

$$\frac{a}{2} \sin \theta = \frac{\lambda}{2}$$

$$a \sin \theta = \lambda$$

$$\sin \theta = \frac{\lambda}{a}$$

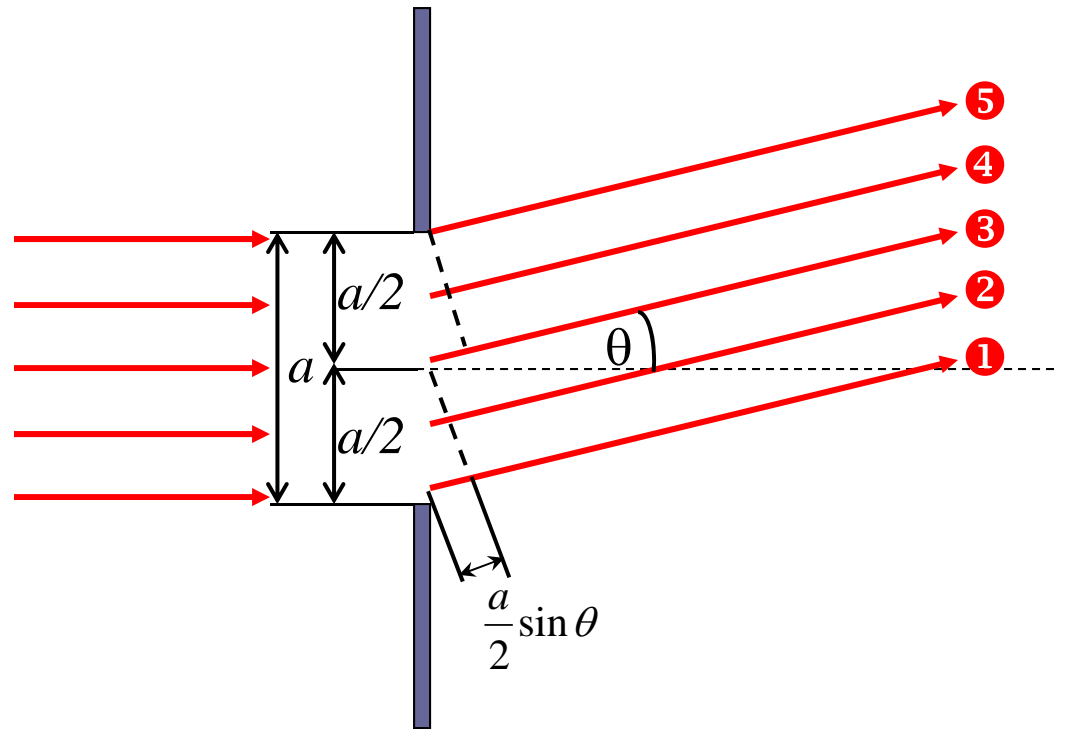

If you divide the slit into 4 equal parts, destructive interference occurs when $\sin \theta = \frac{2\lambda}{a}$.

If you divide the slit into 6 equal parts, destructive interference occurs when $\sin \theta = \frac{3\lambda}{a}$.

In general, destructive interference occurs when

$$a \sin \theta = m \lambda \quad m = 1, 2, 3, \dots$$

- gives positions of dark fringes
- **no** dark fringe for $m=0$

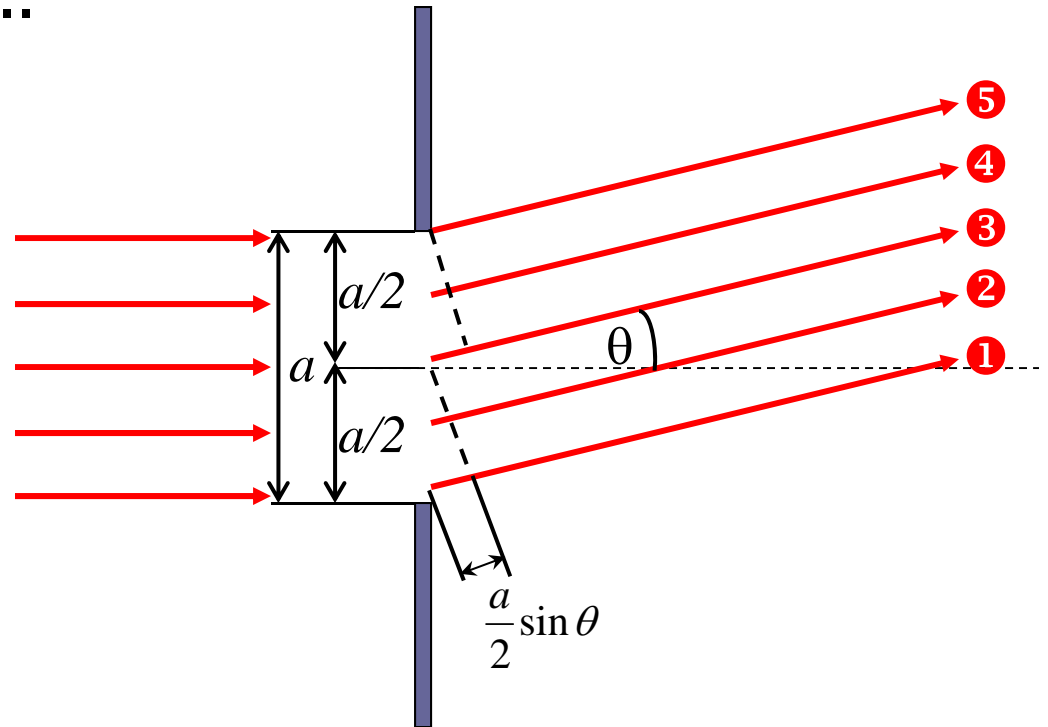

The bright fringes are **approximately** halfway in between.

[Applet.](#)

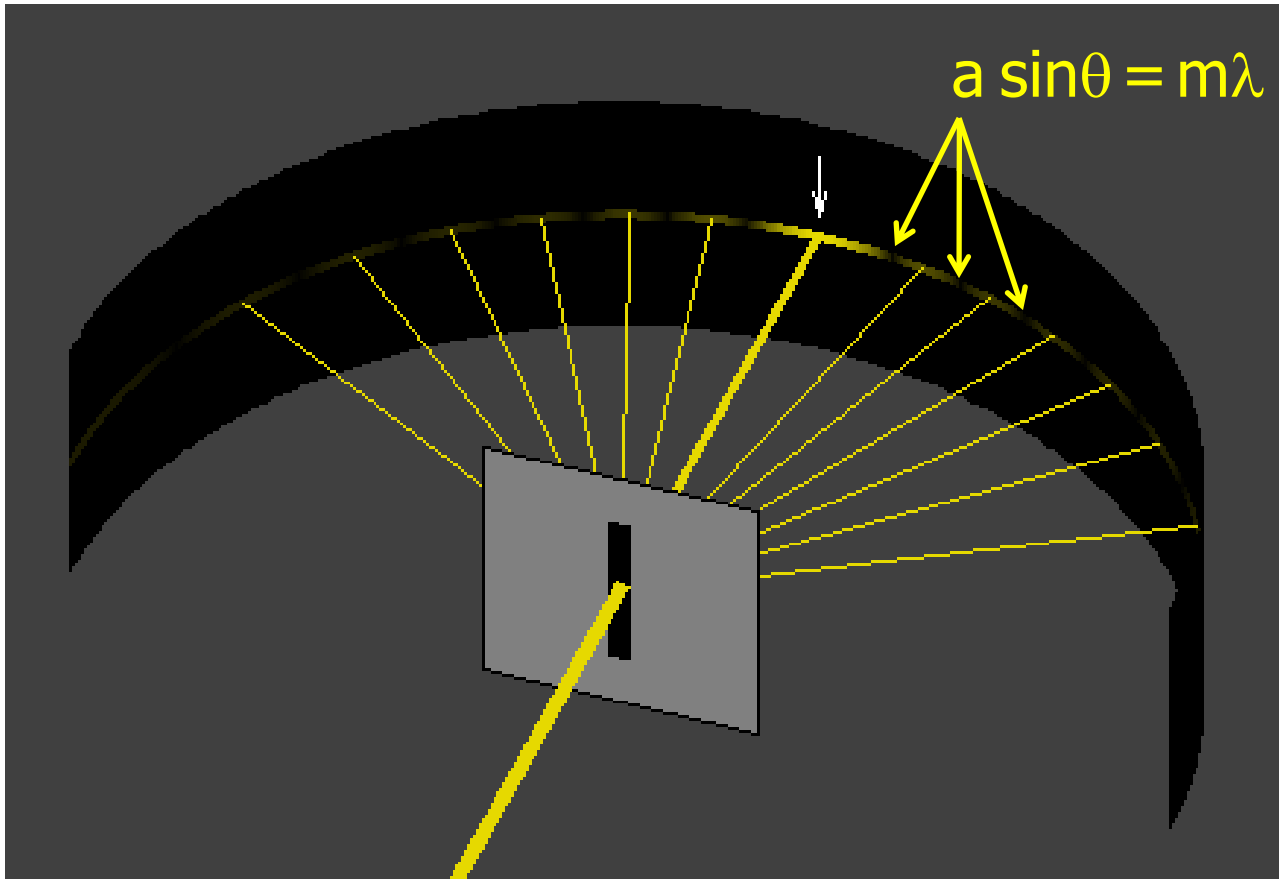

<http://www.walter-fendt.de/ph14e/singleslit.htm>

Use this geometry for tomorrow's **single-slit** homework problems.

If θ is small,* then it is valid to use the approximation $\sin \theta \approx \theta$. (θ must be expressed in radians.)

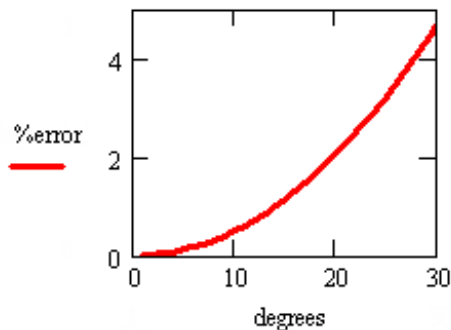
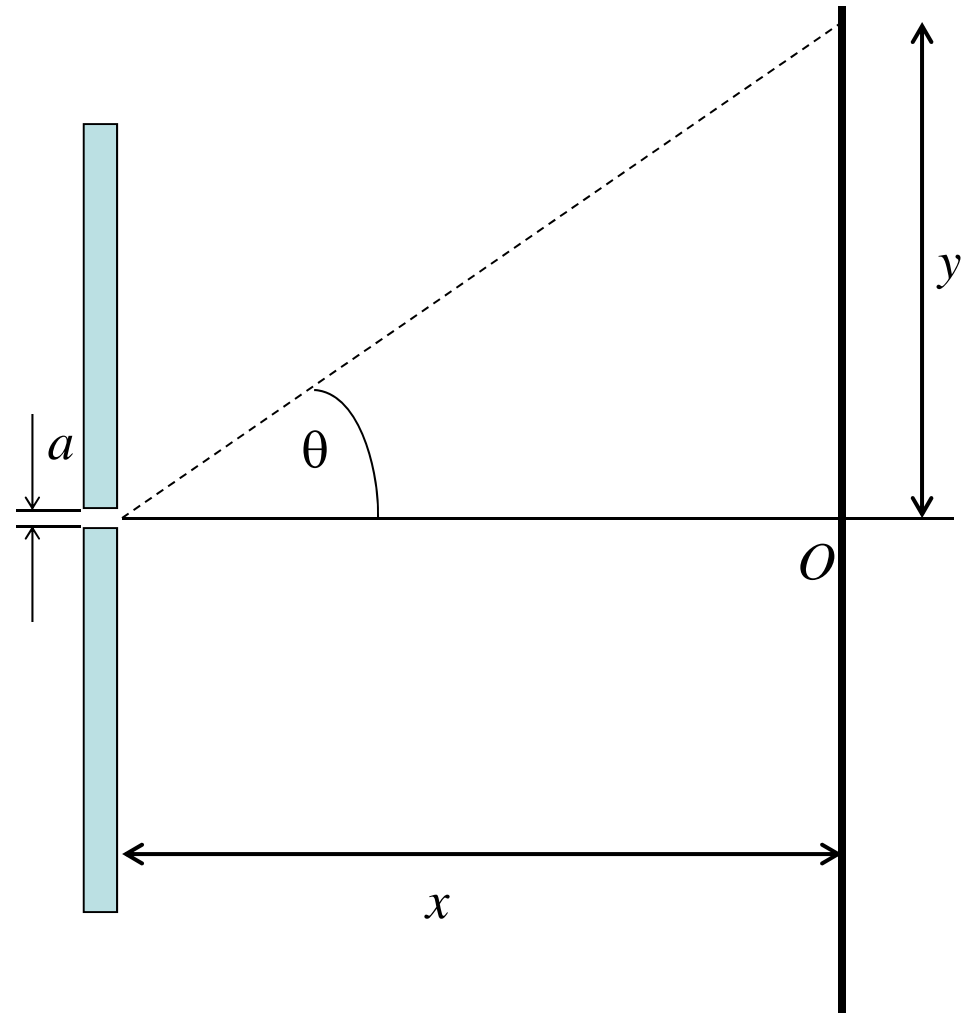

*The approximation is quite good for angles of 10° or less, and not bad for even larger angles.

Single Slit Diffraction Intensity

Your text gives the intensity distribution for the single slit. The general features of that distribution are shown below.

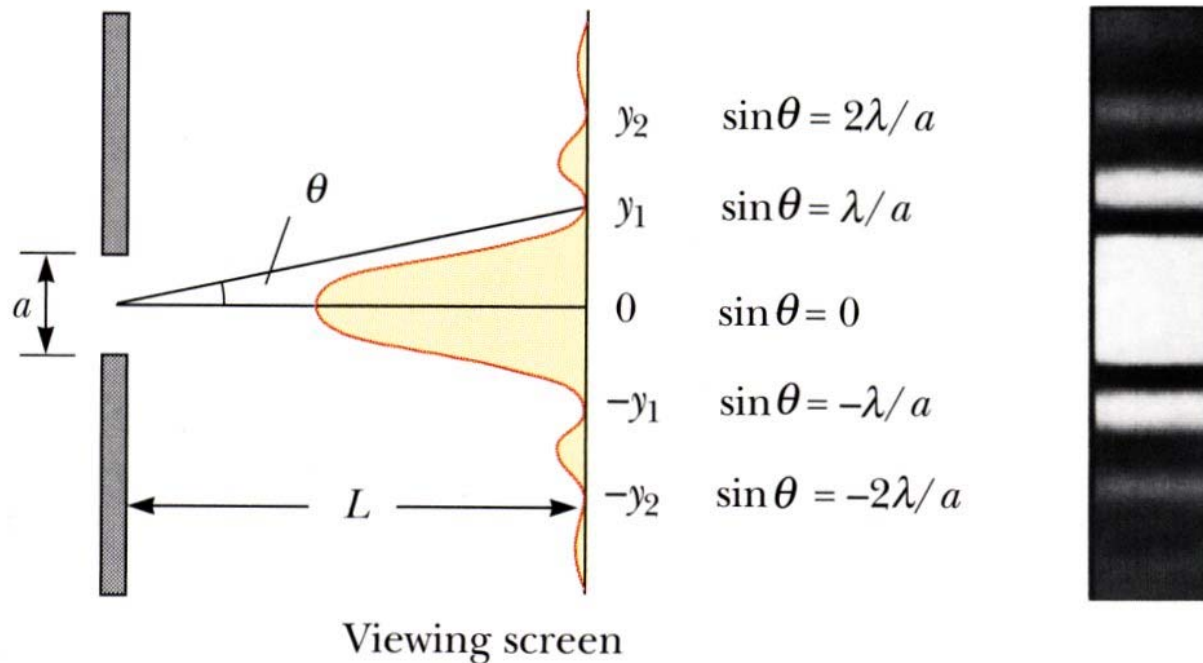

Most of the intensity is in the central maximum. It is twice the width of the other (secondary) maxima.

Starting equations for single-slit intensity:

$$\beta = \frac{2\pi}{\lambda} a \sin\theta$$

$$I = I_0 \left[\frac{\sin(\beta/2)}{(\beta/2)} \right]^2$$

"Toy"

Example: 633 nm laser light is passed through a narrow slit and a diffraction pattern is observed on a screen 6.0 m away. The distance on the screen between the centers of the first minima outside the central bright fringe is 32 mm. What is the slit width?

$$y_1 = (32 \text{ mm})/2 \quad \tan\theta = y_1/L \quad \tan\theta \approx \sin\theta \approx \theta \text{ for small } \theta$$

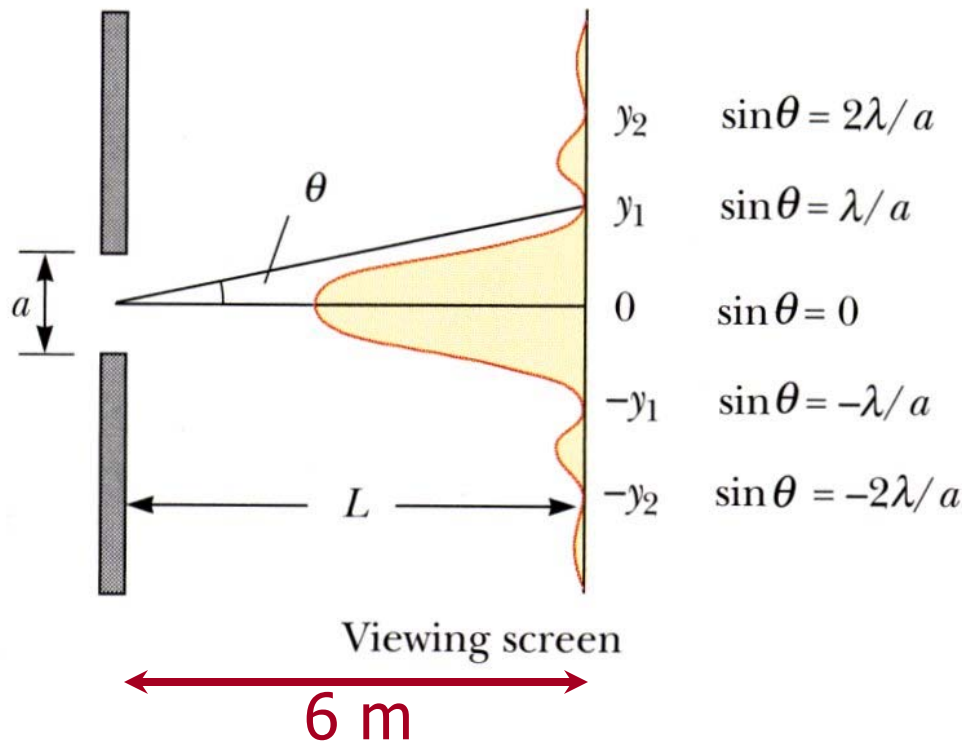

$$a \sin\theta = m\lambda = (1)\lambda$$

$$\sin\theta = \frac{\lambda}{a} \Rightarrow a = \frac{\lambda}{\sin\theta} \approx \frac{\lambda}{y_1/L} = \frac{L\lambda}{y_1}$$

$$a = \frac{(6.0 \text{ m})(633 \times 10^{-9} \text{ m})}{(16 \times 10^{-3} \text{ m})}$$

$$a = 2.37 \times 10^{-4} \text{ m}$$

Resolution of Single Slit (and Circular Aperture)

The ability of optical systems to distinguish closely spaced objects is limited because of the wave nature of light.

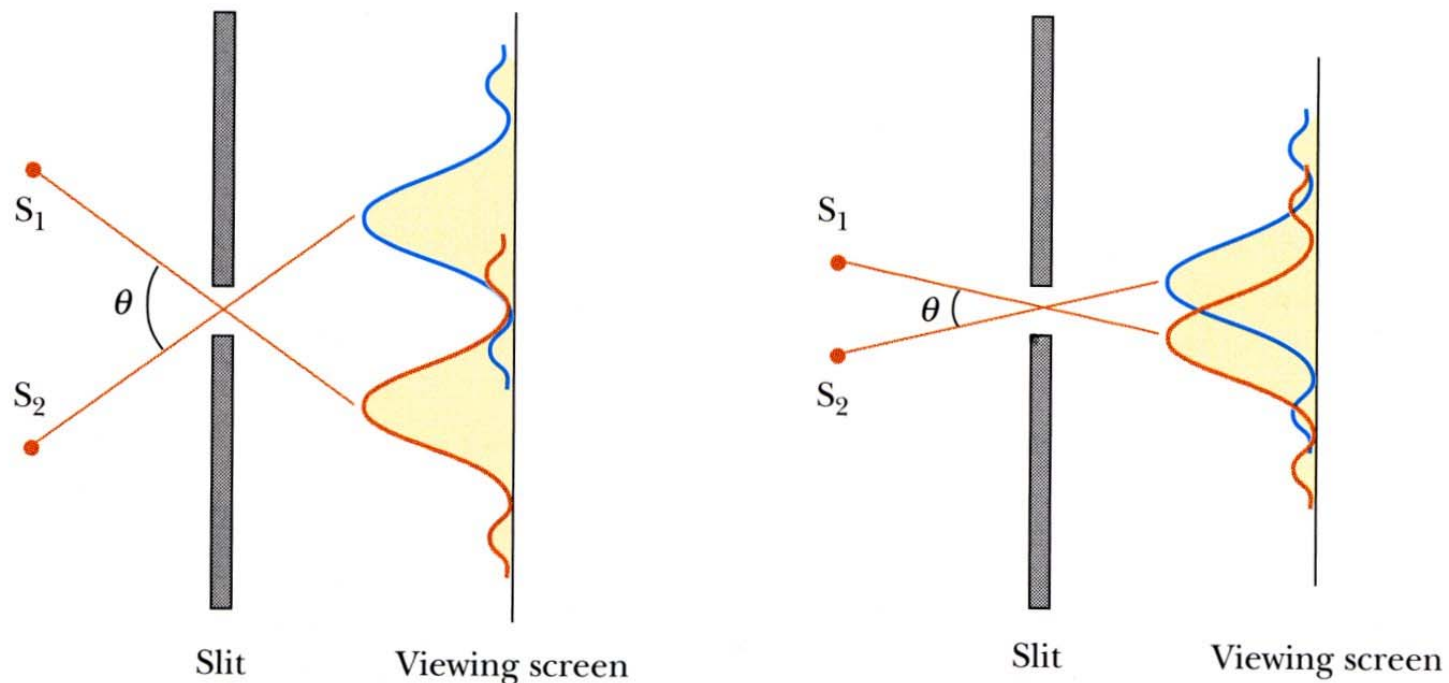

If the sources are far enough apart so that their central maxima do not overlap, their images can be distinguished and they are said to be *resolved*.

When the central maximum of one image falls on the first minimum of the other image the images are said to be *just* resolved. This limiting condition of resolution is called *Rayleigh's criterion*.

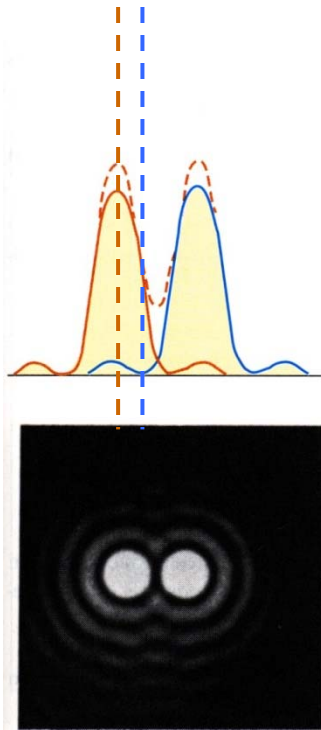

From Rayleigh's criterion:

minimum angular separation of sources for which the images are resolved.

slit of width a :

$$\theta = \frac{\lambda}{a}$$

circular aperture of diameter D :

$$\theta = \frac{1.22 \lambda}{D}$$

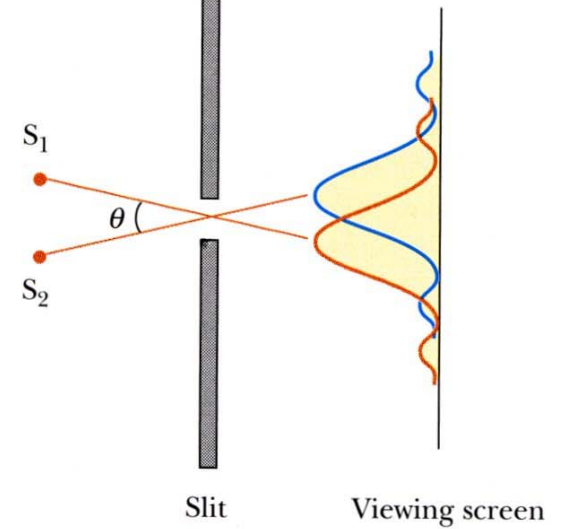
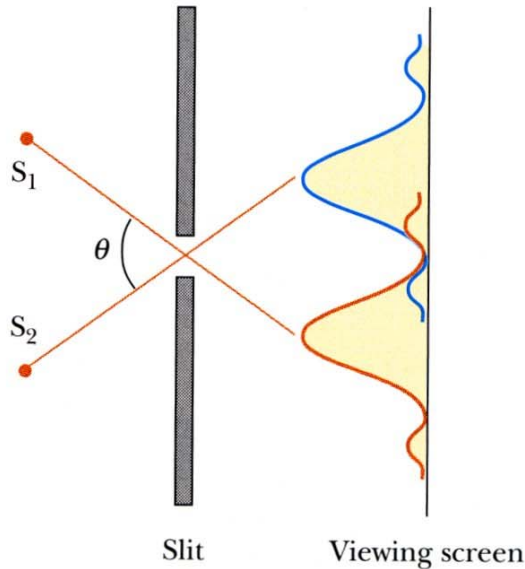

Resolution is wavelength limited!

These come from $a = \lambda / \sin\theta$
the small angle approximation,
and geometry.

Photography:

closing the aperture too much
leads to unsharp pictures

If a single slit diffracts, what about a double slit?

Remember the double-slit interference pattern from the chapter on interference?

$$I = I_{\max} \cos^2 \left(\frac{\pi d \sin \theta}{\lambda} \right)$$

If **slit width** (not spacing between slits) is **not infinitesimally small** but comparable to wavelength, you must account for diffraction.

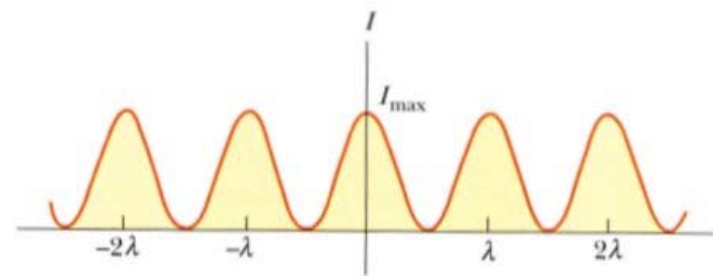
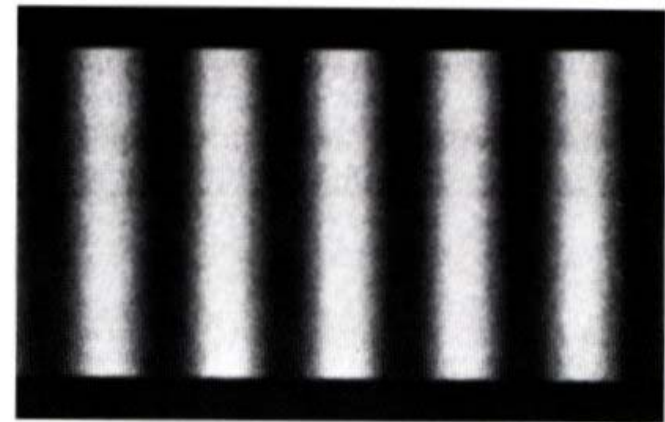

interference only

Double Slit Diffraction with $a \approx \lambda$

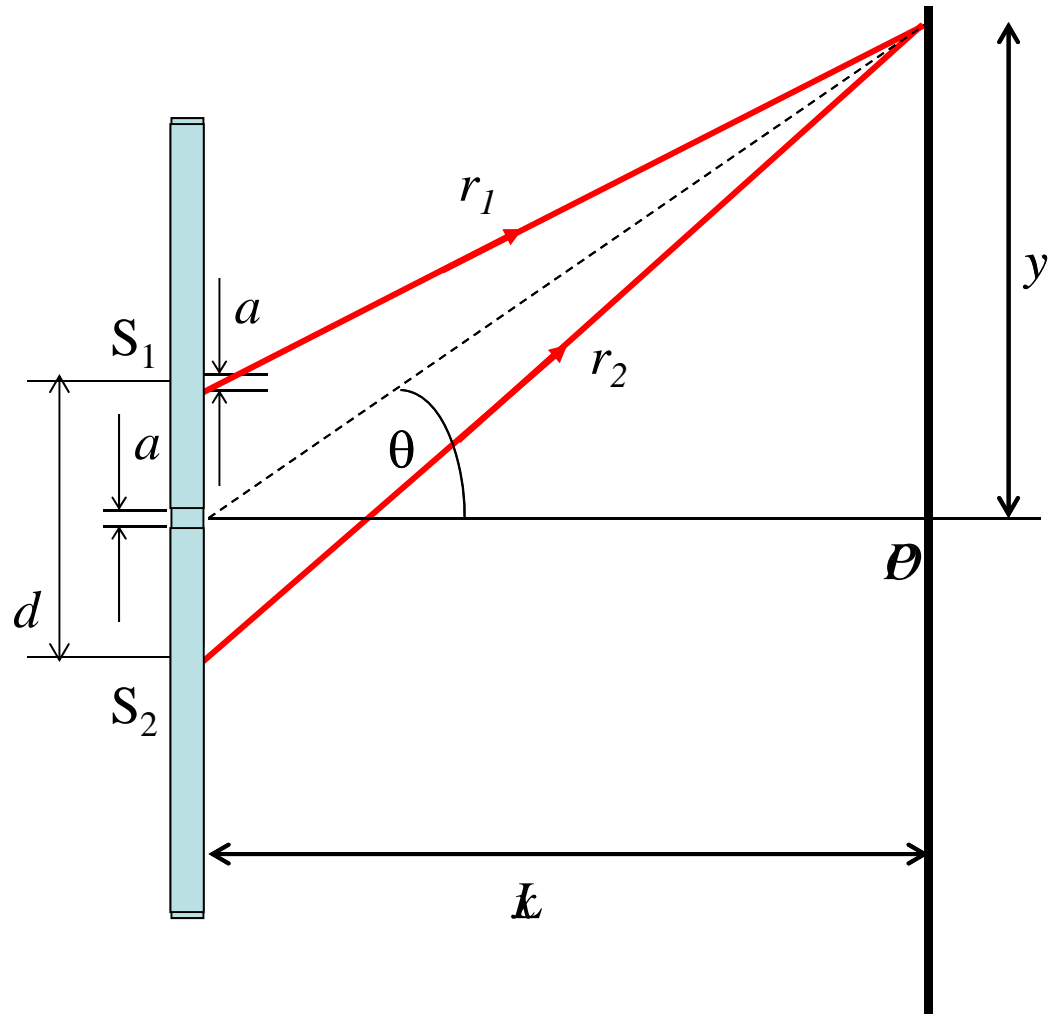

Diffraction Gratings

diffraction grating: large number of equally spaced parallel slits

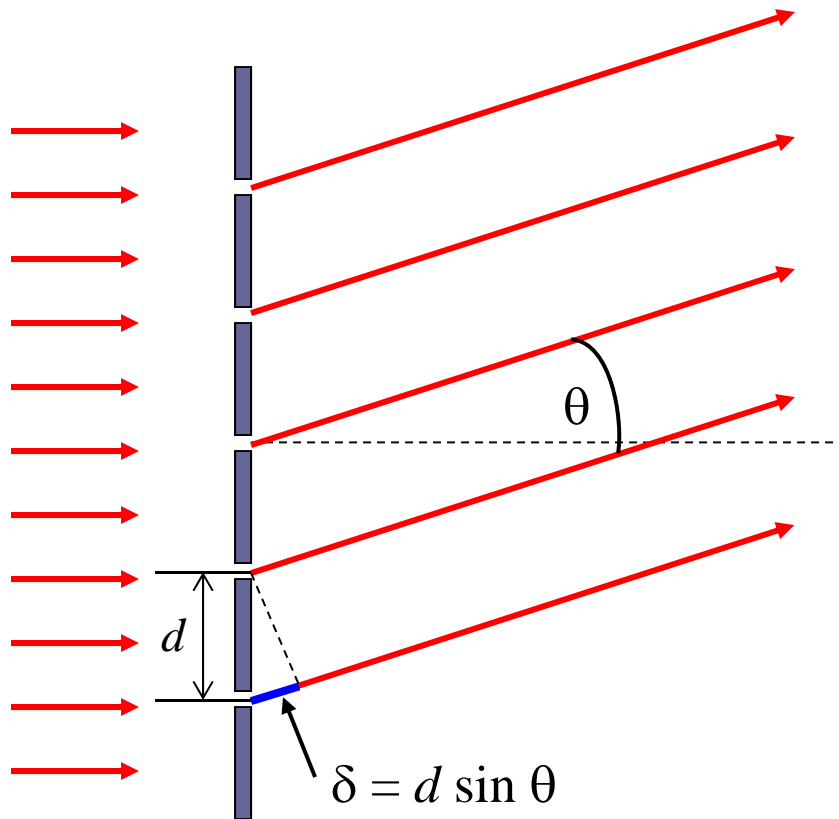

The path difference between rays from **any** two adjacent

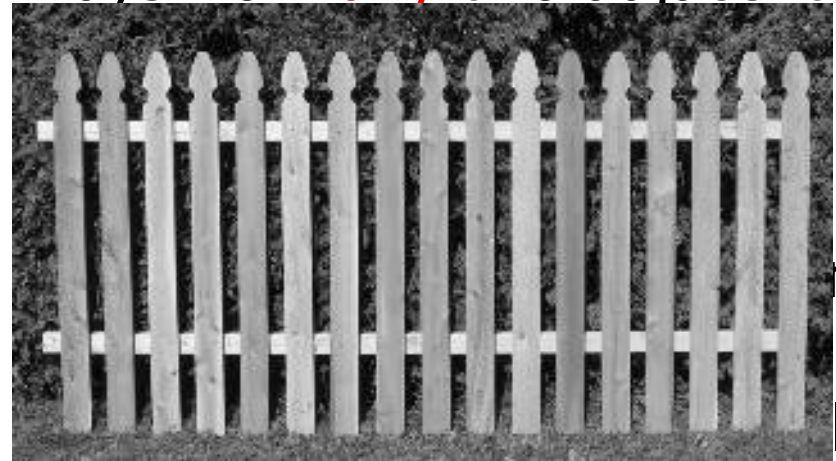

arrive in phase at a point on a distant screen.

Interference maxima occur for $d \sin \theta = m\lambda$, $m = 1, 2, 3, \dots$

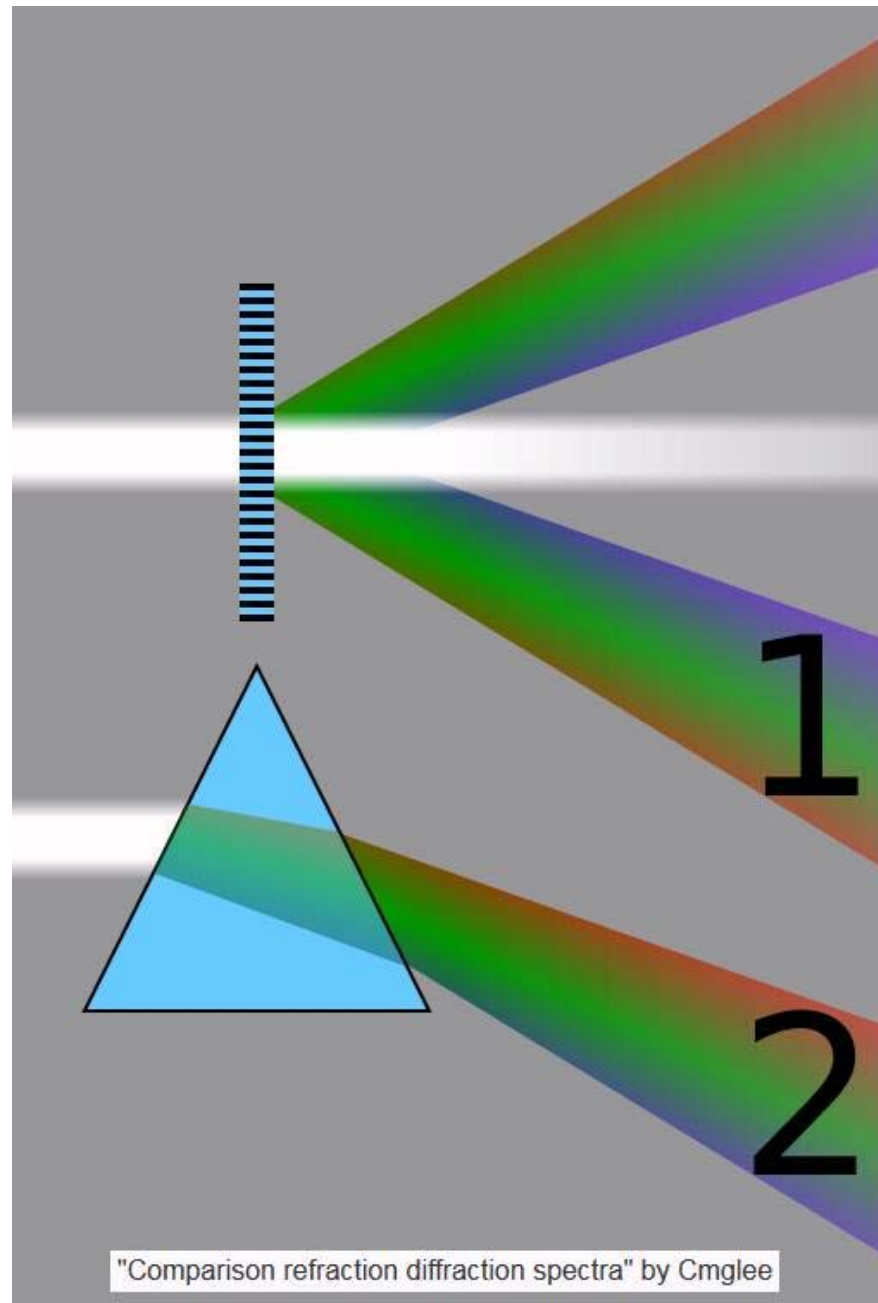

Diffraction is not the same as refraction!

Ok what's with this equation monkey business?

$$d \sin\theta = m\lambda, \quad m = 1, 2, 3, \dots$$

double-slit interference
constructive

$$a \sin\theta = m\lambda, \quad m = 1, 2, 3, \dots$$

single-slit diffraction
destructive!

$$d \sin\theta = m\lambda, \quad m = 1, 2, 3, \dots$$

diffraction grating
constructive

$d \Rightarrow$ double slit and diffraction

$a \Rightarrow$ a single slit but destructive

Diffraction Grating Intensity Distribution

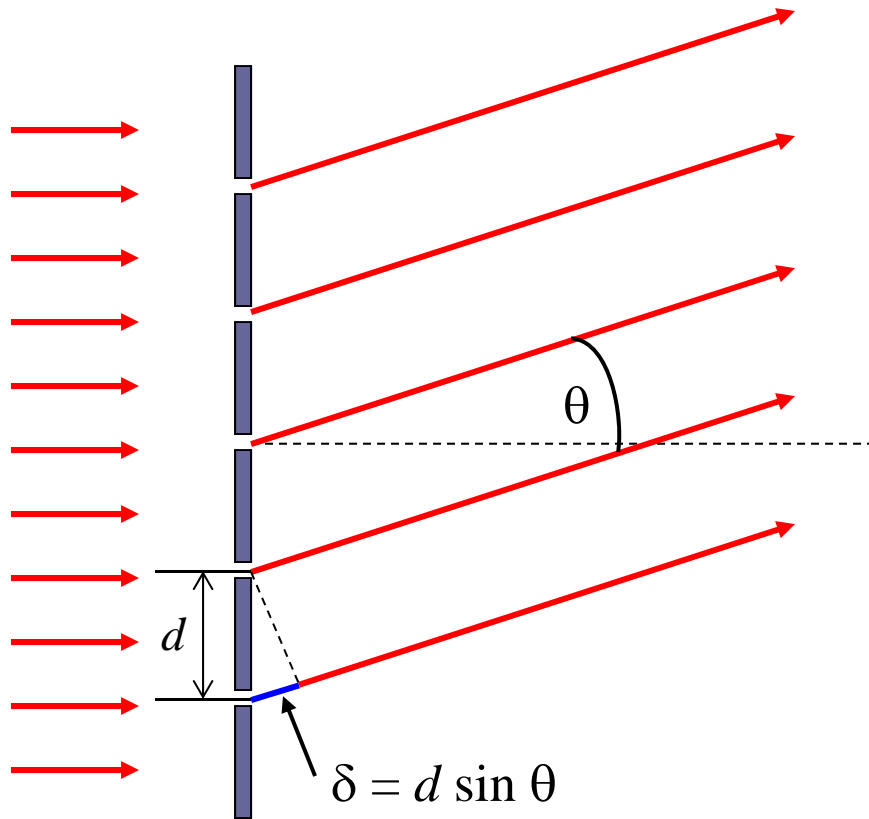

Interference Maxima:

$$d \sin \theta = m \lambda$$

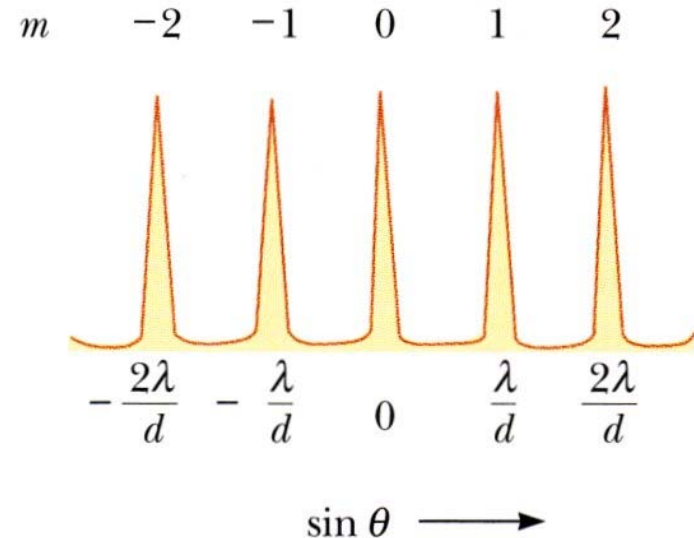

The intensity maxima are brighter and sharper than for the two slit case. See [here](#) and [here](#).

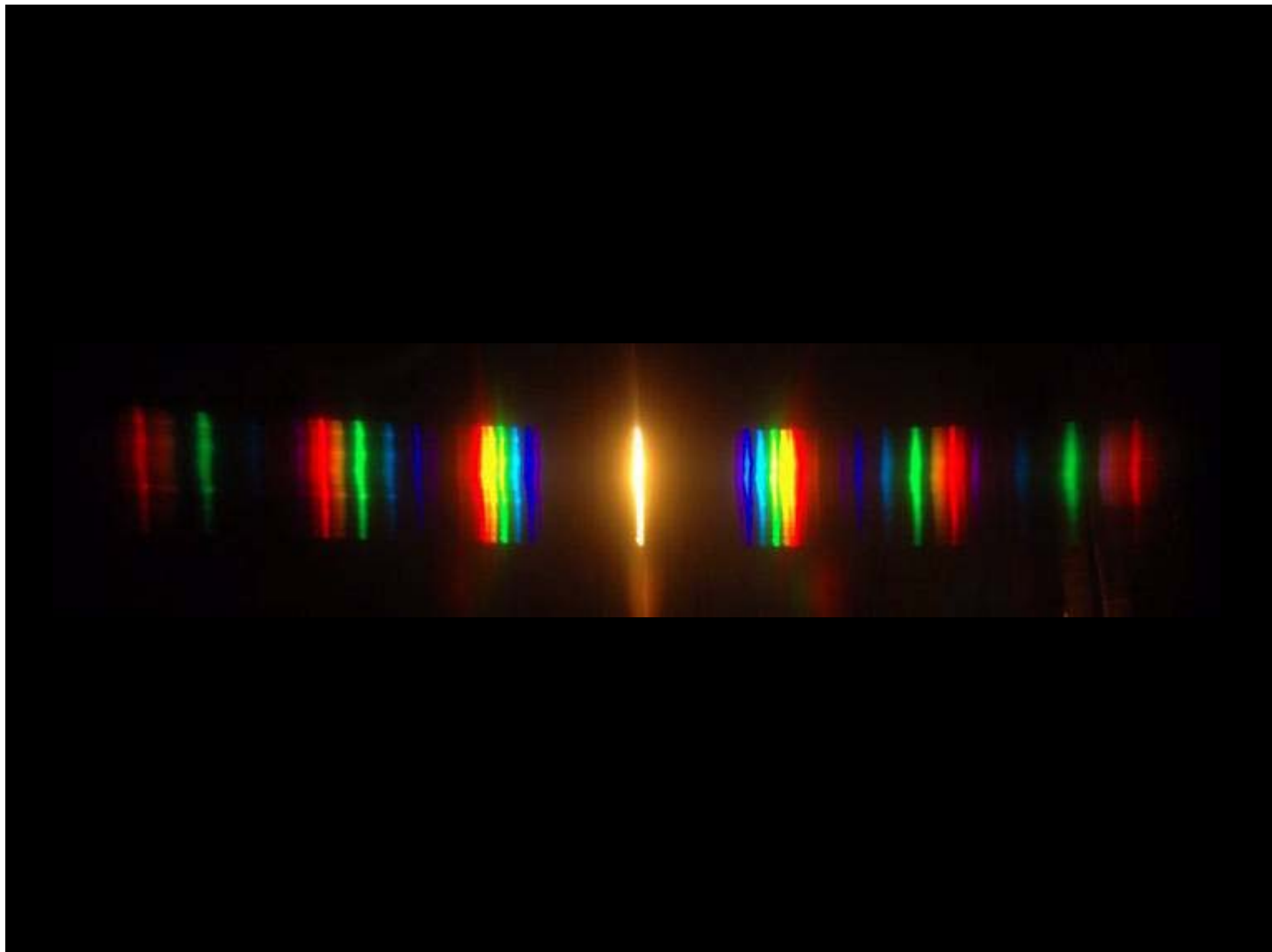

Application: spectroscopy



visible light



hydrogen



helium



mercury

You can view the atomic spectra for each of the elements [here](#).

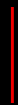
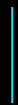
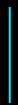

White Light Source

Diffraction Grating

Spectrum

<http://h2physics.org/?cat=49>

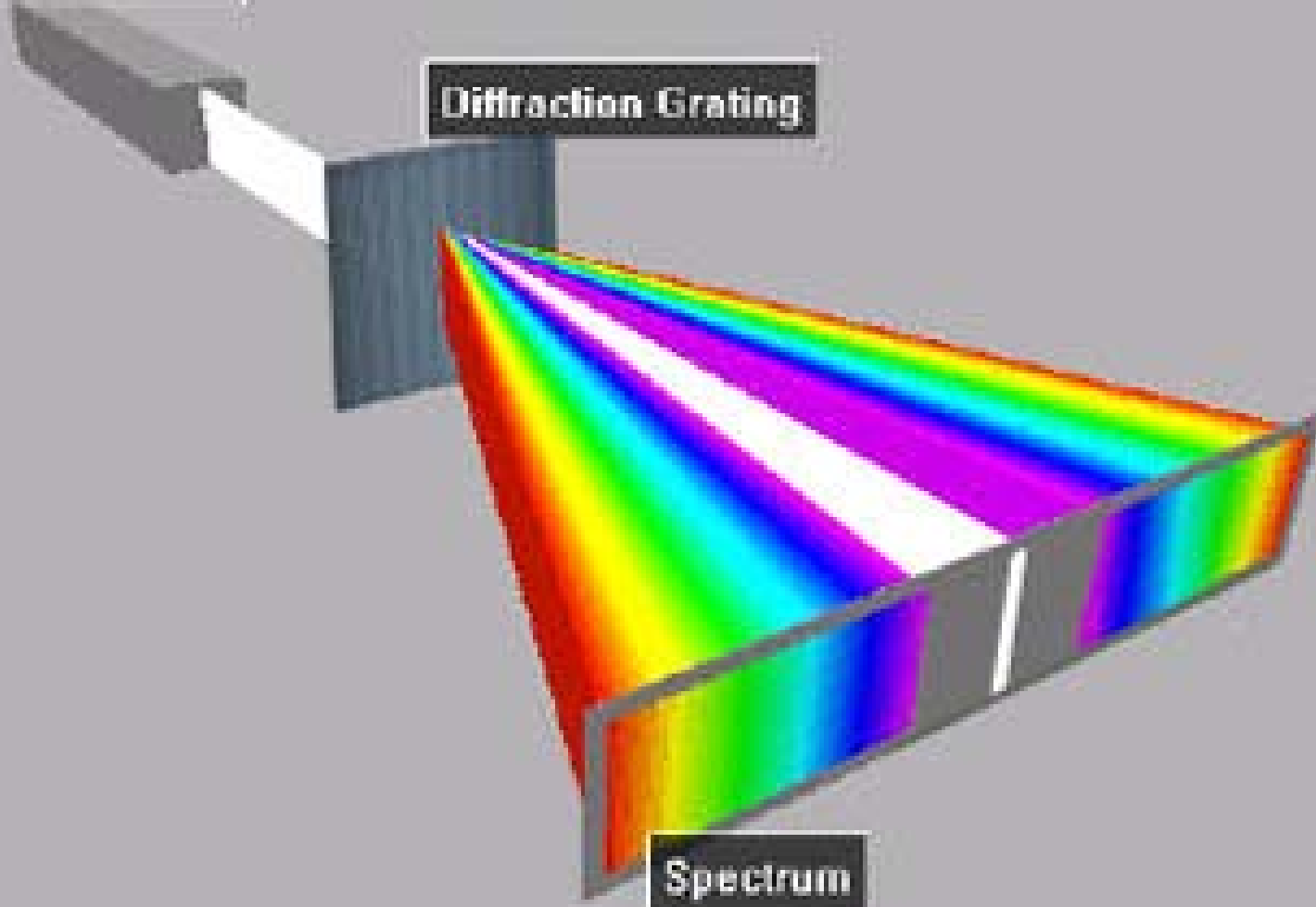

Example: the wavelengths of visible light are from approximately 400 nm (violet) to 700 nm (red). Find the angular width of the first-order visible spectrum produced by a plane grating with 600 slits per millimeter when white light falls normally on the grating.

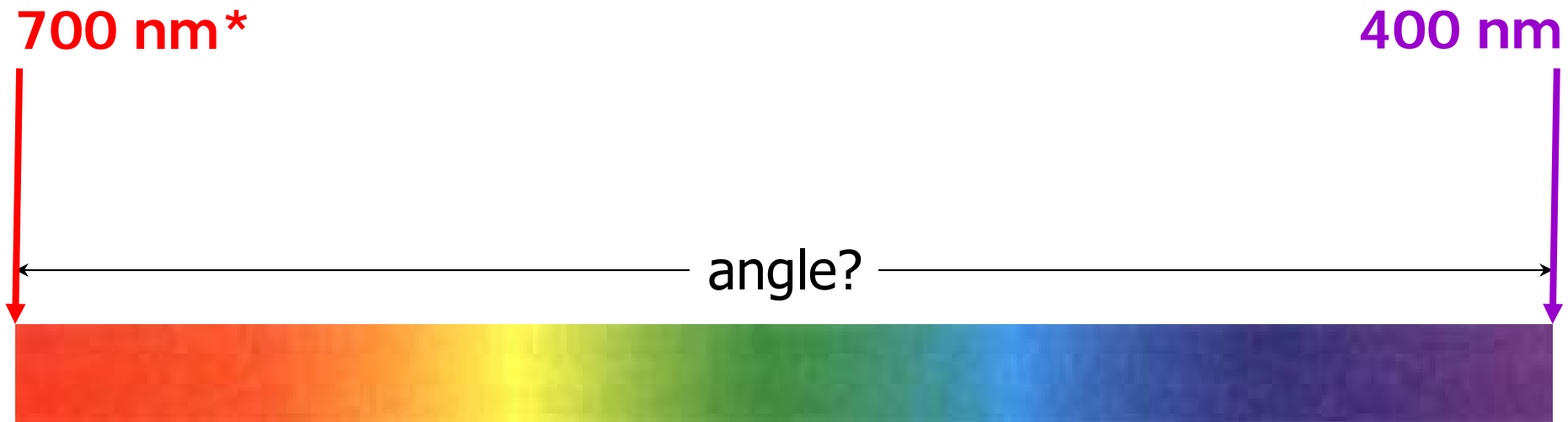

*Or 750 nm, or 800 nm, depending on who is observing.

Example: the wavelengths of visible light are from approximately 400 nm (violet) to 700 nm (red). Find the angular width of the first-order visible spectrum produced by a plane grating with 600 slits per millimeter when white light falls normally on the grating.

Interference Maxima: $d \sin\theta = m\lambda$

$$d = \frac{1}{600 \text{ slits/mm}} = 1.67 \times 10^{-6} \text{ m}$$

First-order violet:

$$\sin \theta_v = m \frac{\lambda_v}{d} = \frac{(1)(400 \times 10^{-9} \text{ m})}{1.67 \times 10^{-6} \text{ m}} = 0.240$$

$$\theta_v = 13.9^\circ$$

First-order red:

$$\sin \theta_R = m \frac{\lambda_R}{d} = \frac{(1)(700 \times 10^{-9} \text{ m})}{1.67 \times 10^{-6} \text{ m}} = 0.419$$

$$\theta_R = 24.8^\circ$$

$$\Delta\theta = \theta_R - \theta_V = 24.8^\circ - 13.9^\circ = 10.9^\circ$$

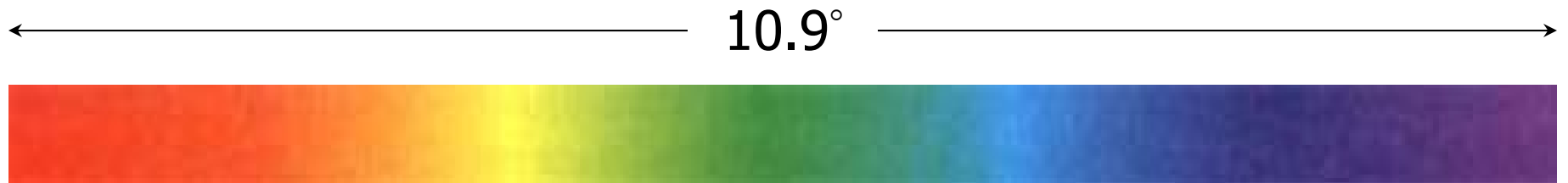

Application: use of diffraction to probe materials.

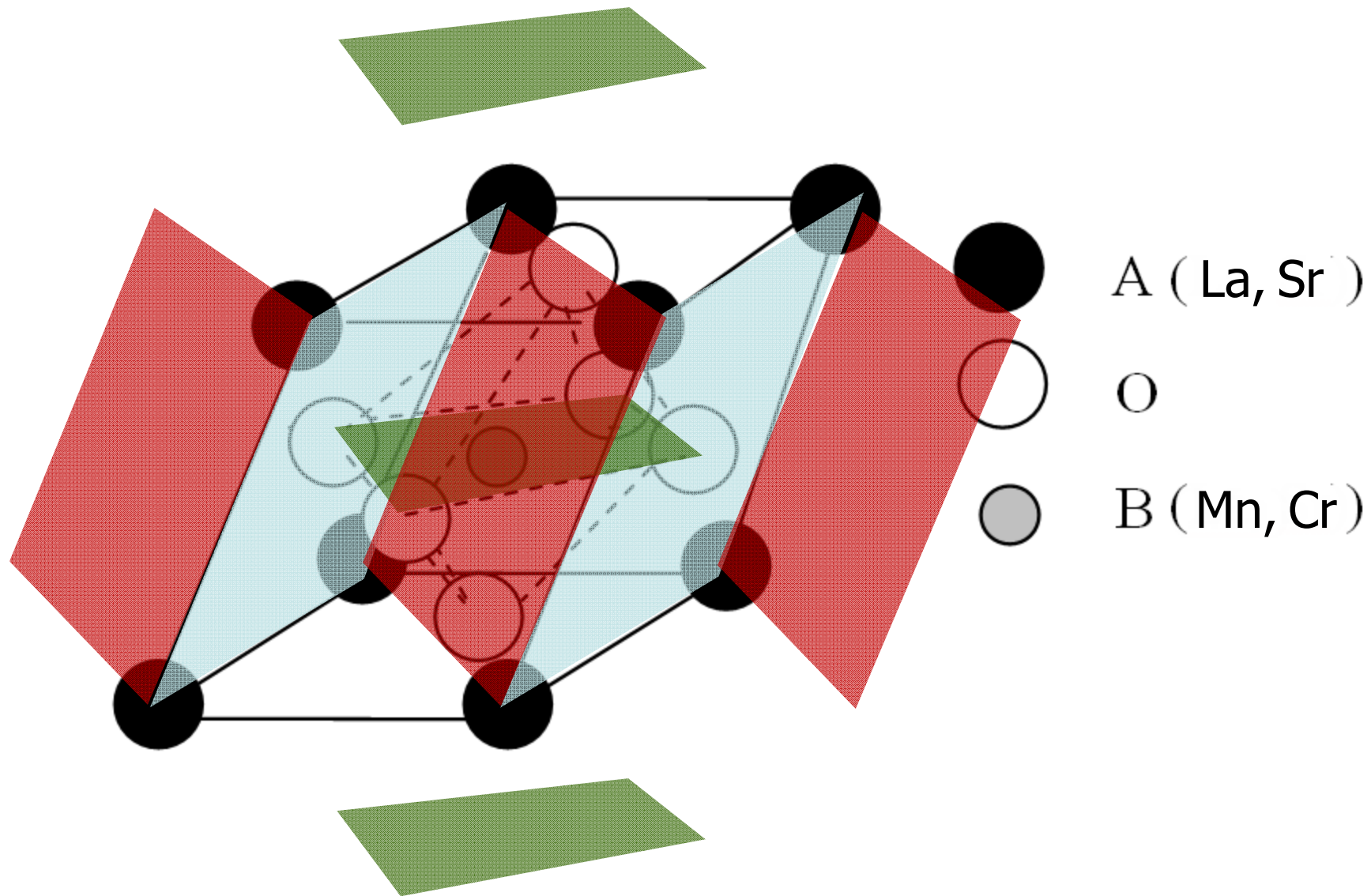

Application: use of diffraction to probe materials.

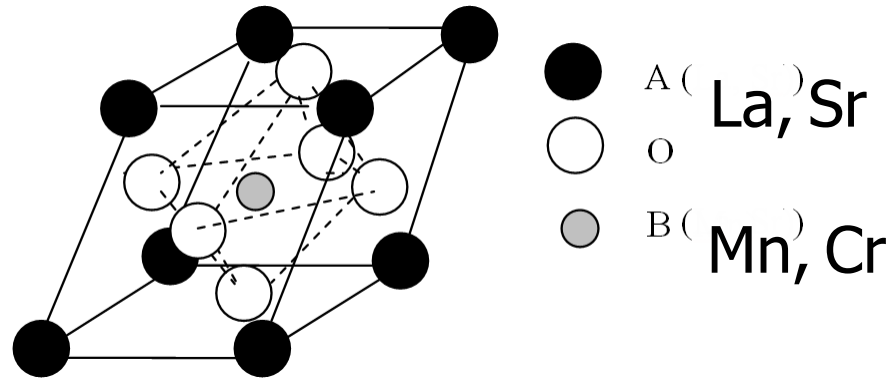

Shoot a beam of x-rays or neutrons at an unknown material.
The x-rays or neutrons diffract.

Positions of peaks tell you what sets of planes exist in the material. From this you can infer the crystal structure.

Intensities of peaks tell you atoms lie on the different planes, and where they are located on the planes.

Application: use of diffraction to probe materials.

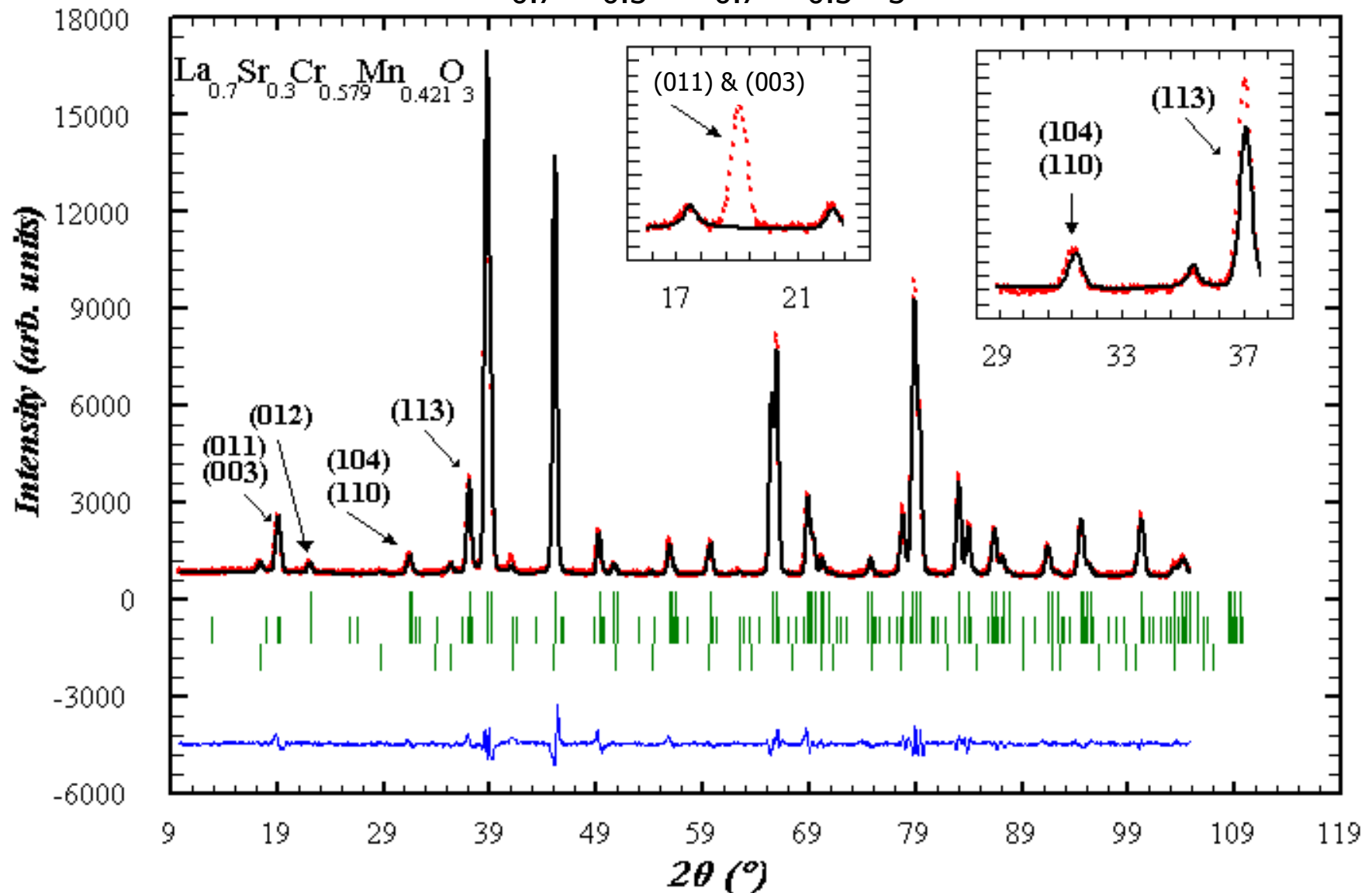

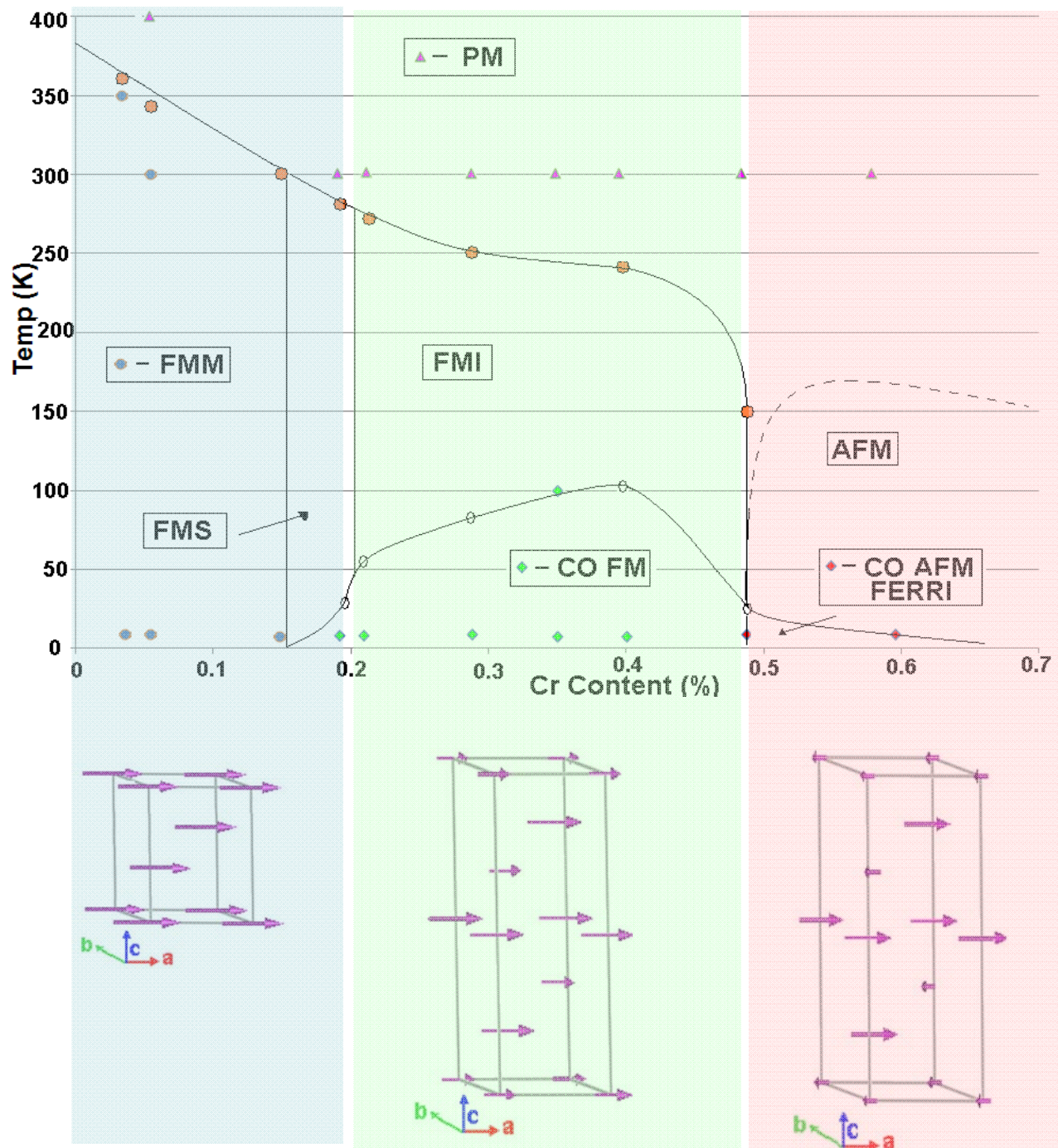

Diffraction Grating Resolving Power

Diffraction gratings let us measure wavelengths by separating the diffraction maxima associated with different wavelengths. In order to distinguish two nearly equal wavelengths the diffraction must have sufficient resolving power, R .

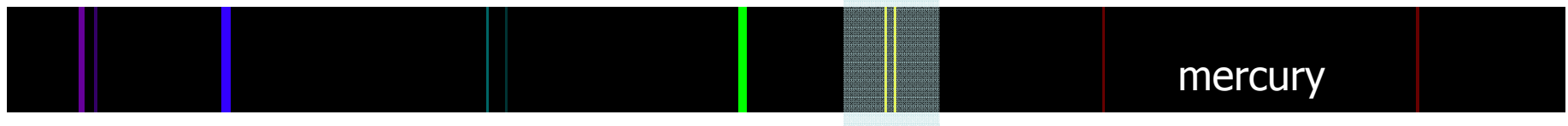

Consider two wavelengths λ_1 and λ_2 that are nearly equal.

The average wavelength is $\lambda_{\text{avg}} = \frac{\lambda_1 + \lambda_2}{2}$ and the difference is $\Delta\lambda = \lambda_2 - \lambda_1$.

The resolving power is defined as $R = \frac{\lambda_{\text{avg}}}{\Delta\lambda}$. definition of resolving power

$$R = \frac{\lambda_{\text{avg}}}{\Delta\lambda}$$

For a grating with N lines illuminated it can be shown that the resolving power in the mth order diffraction is

$$R = Nm.$$

resolving power
needed to resolve mth order

Dispersion

Spectroscopic instruments need to resolve spectral lines of nearly the same wavelength.

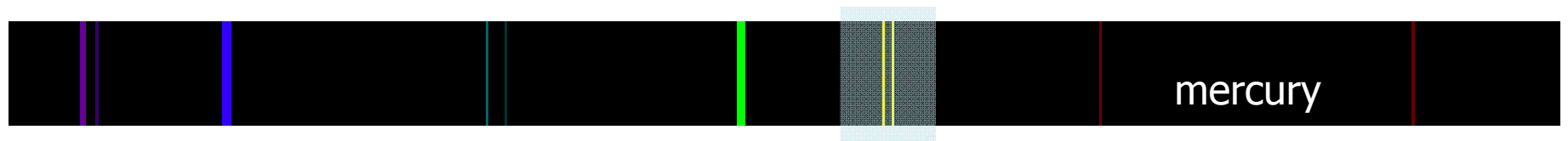

$$\text{angular dispersion} = \frac{\Delta\theta}{\Delta\lambda}$$

The greater the angular dispersion,
the better a spectrometer is at
resolving nearby lines.

Example: Light from mercury vapor lamps contain several wavelengths in the visible region of the spectrum including two yellow lines at 577 and 579 nm. What must be the resolving power of a grating to distinguish these two lines?



$$\lambda_{\text{avg}} = \frac{577 \text{ nm} + 579 \text{ nm}}{2} = 578 \text{ nm}$$

$$\Delta\lambda = 579 \text{ nm} - 577 \text{ nm} = 2 \text{ nm}$$

$$R = \frac{\lambda_{\text{avg}}}{\Delta\lambda} = \frac{578 \text{ nm}}{2 \text{ nm}} = 289$$

Example: how many lines of the grating must be illuminated if these two wavelengths are to be resolved in the first-order spectrum?

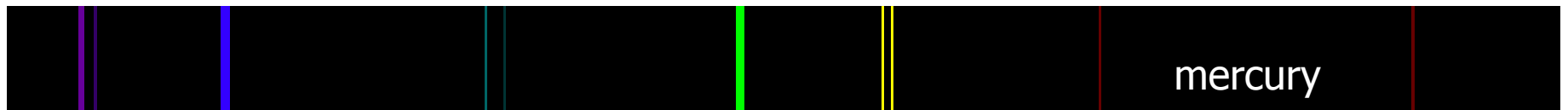

$$R = 289$$

$$R = Nm \Rightarrow N = \frac{R}{m} = \frac{289}{1} = 289$$