

# Exam 3: Tuesday, April 17, 5:00-6:00 PM

## Test rooms:

<b>Instructor</b>	<b>Sections</b>	<b>Room</b>
Dr. Madision	E, G	McNutt 204
Dr. Parris	J, L	Toomey 199
Mr. Upshaw	B, H, K, N	Schrenk G3
Dr. Vojta	A, D	Physics 104
Dr. Wilemski	F, M	BCH 125

Today's agenda:

## **Introduction to Light.**

You must develop a general understanding of what light is and how it behaves.

## **Reflection and Refraction (Snell's Law).**

You must be able to determine the path of light rays using the laws of reflection and refraction.

## **Total Internal Reflection and Fiber Optics.**

You must be able to determine the conditions under which total internal reflection occurs, and apply total internal reflection to fiber optic and similar materials.

## **Dispersion.**

You must understand that the index of refraction of a material is wavelength-dependent.

# What is Light?

**Optics:** physics of light

- different layers of understanding/describing light

**Geometric optics:**

- light consists of **rays**, moves in straight line until it hits interface
- arose in ancient Greece ~300BC (οπτική = appearance)
- greatly developed in Persia in the middle ages  
(in 984, mathematician Ibn Sahl wrote treatise "On burning mirrors and lenses" that contained a version of Snell's law)

## **Wave optics:**

- light is a wave phenomenon (Huygens 1690)
- new effects beyond geometric optics: interference
- later: light is **electromagnetic** wave
- unified with theory of electromagnetism by Maxwell (1860s)

## **Modern (quantum) optics:**

- light is not just a wave but at the same time consists of particles, the **photons**
- started by Planck and Einstein around 1900
- many new phenomena, e.g., the laser

## **In this course:**

geometric optics and wave optics, for quantum optics take Physics 2305 "Introduction To Modern Physics"

## Reminder:

Visible light is a small part of the electromagnetic spectrum.

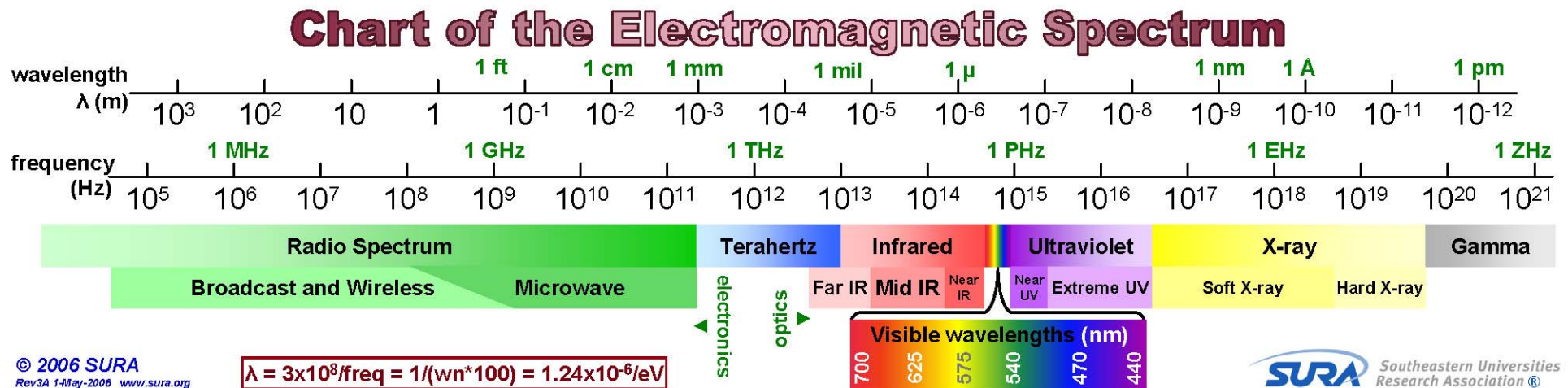

Wavelengths of visible light: 400 nm (violet) to 700 nm (red)

# Geometric Optics

- occupies first half of optics part of Physics 2135
- light consists of **rays** (infinitely thin beams of light)
- in vacuum or in **uniform** medium, ray is a **straight** line
- if medium is **not uniform** (for example at a surface), ray can be **curved or bent**
- we can see an object if rays emitted by the object enter our eyes  
(if you can see something, it must be a source of light!)

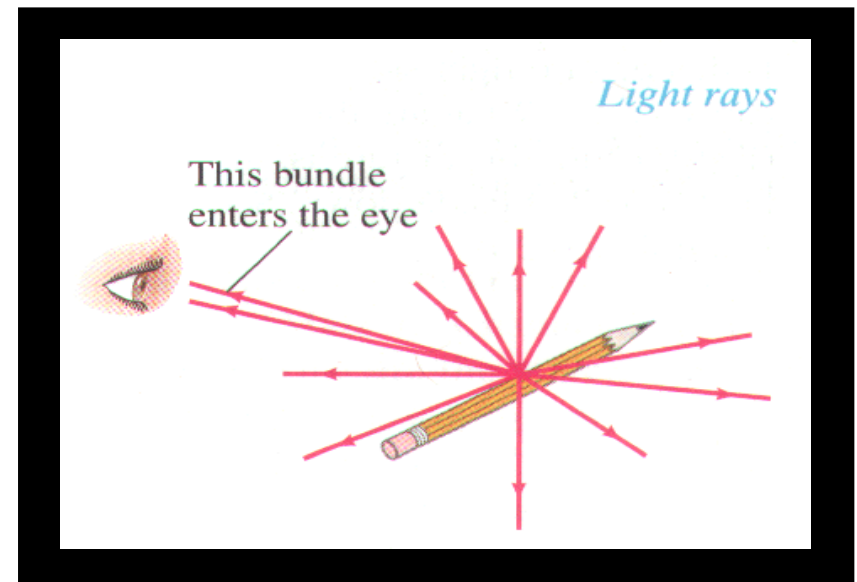

Today's agenda:

## Introduction to Light.

You must develop a general understanding of what light is and how it behaves.

## **Reflection and Refraction (Snell's Law).**

You must be able to determine the path of light rays using the laws of reflection and refraction.

## Total Internal Reflection and Fiber Optics.

You must be able to determine the conditions under which total internal reflection occurs, and apply total internal reflection to fiber optic and similar materials.

## Dispersion.

You must understand that the index of refraction of a material is wavelength-dependent.

# Reflection

- light striking a surface may be reflected, transmitted, or absorbed
- reflection from a smooth surface is **specular** (mirror-like)
- reflection from a rough surface is **diffuse** (not mirror-like).

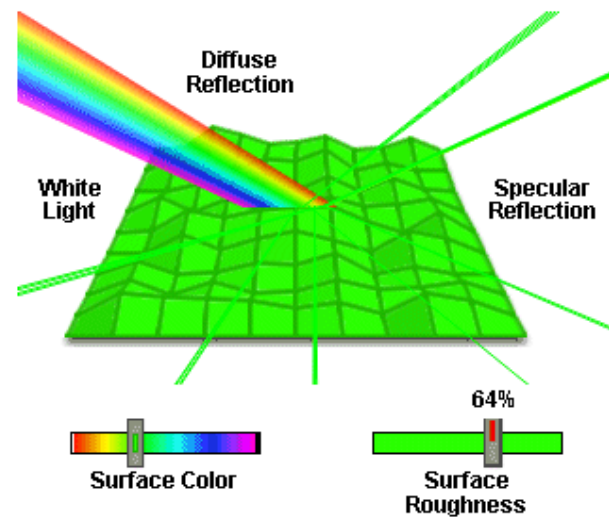
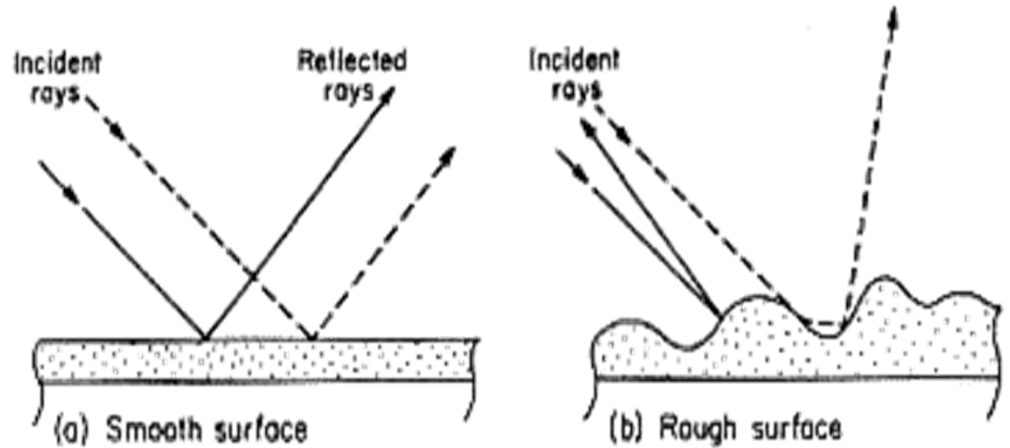

<http://micro.magnet.fsu.edu/primer/java/reflection/specular/index.html/>



## Specular reflection:

- reflected light leaves surface at the same angle it was incident on surface:

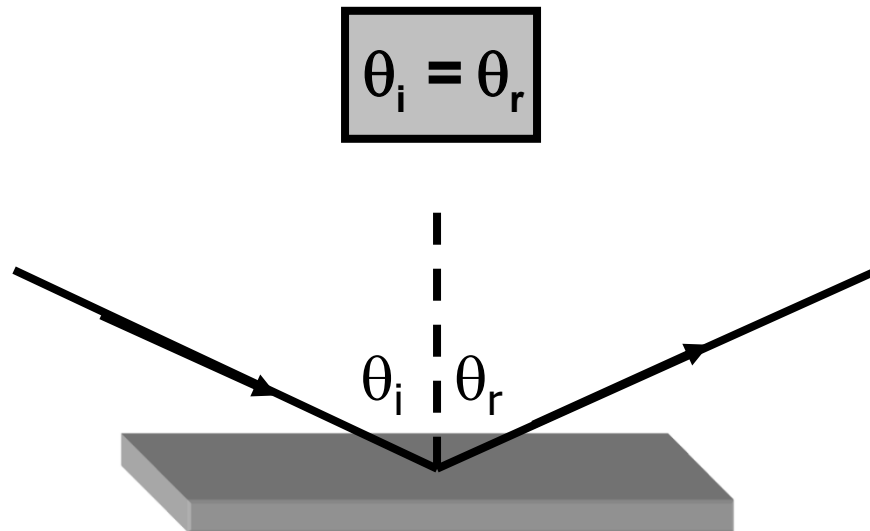

Real Important Note: the angles are measured relative to the surface normal.

# Refraction

- light rays **change direction** (are “refracted”) when they move from one medium to another
- refraction takes place because light travels with different speeds in different media

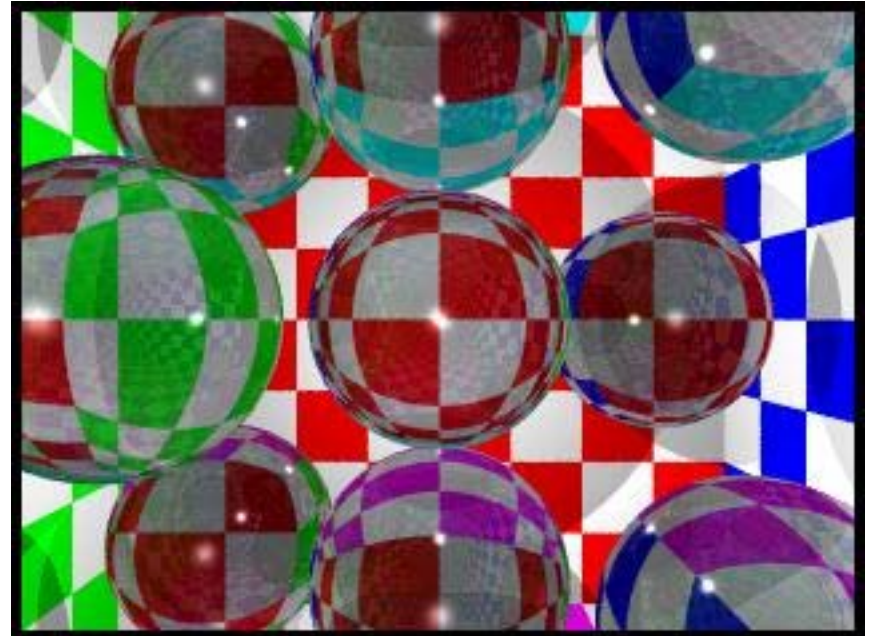

## **Speed of light in vacuum:**

$$c = 2.9979 \times 10^8 \text{ m/s} \quad (\text{just use } 3 \times 10^8 \text{ m/s})$$

- in medium, light moves at speed  $v$ , **slower** than in vacuum
- index of refraction of a material is defined by

$$n = \frac{c}{v}$$

If you study light in advanced classes, you'll find it is more complex than this.

- recall: wave speed  $v = \lambda f$
- **speed** and **wavelength** change when light passes from one medium to another, **frequency** stays the same

$$v = \frac{c}{n} \quad \text{and} \quad \lambda_n = \frac{\lambda}{n}$$

Because light never travels faster than  $c$ ,  $n \geq 1$ . \* For water,  $n = 1.33$  and for glass,  $n \approx 1.5$ . Indices of refraction for several materials are listed in your text.

Example: calculate the speed of light in diamond ( $n = 2.42$ ).

$$v = \frac{c}{n}$$

$$v = \frac{3 \times 10^8 \text{ m/s}}{2.42}$$

$$v = 1.24 \times 10^8 \text{ m/s}$$

\*Actually, not true but don't worry about it unless you take advanced courses in optics.

# Snell's Law

- quantitative description of refracted (bent) ray

$\theta_a$ : angle of incidence,  $\theta_b$ : angle of refraction

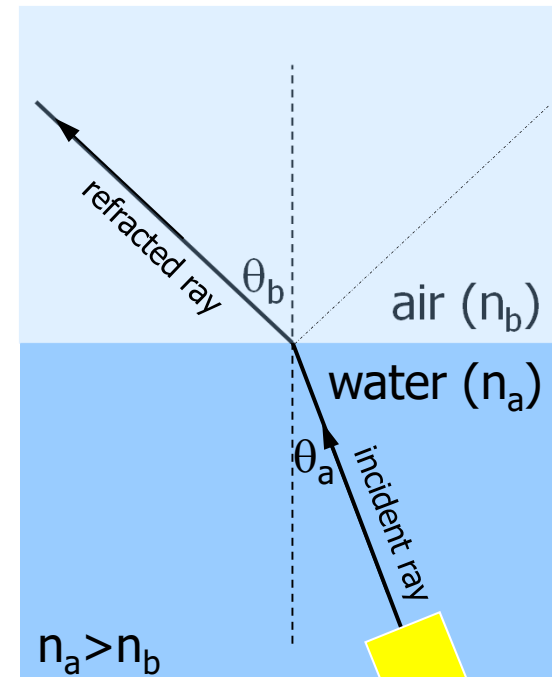
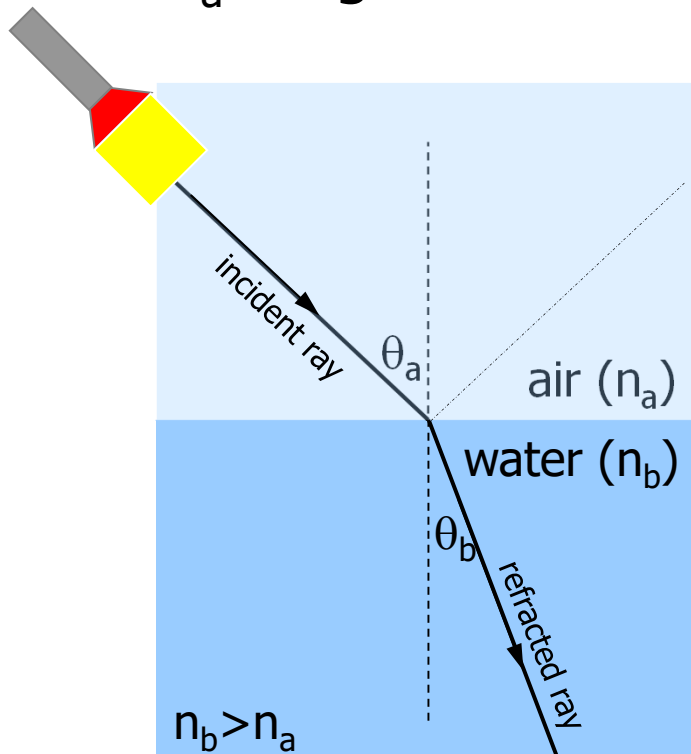

$$n_a \sin(\theta_a) = n_b \sin(\theta_b)$$

Light passing from air ( $n \approx 1$ ) into water ( $n \approx 1.33$ ).

Light “bends” towards the normal to the surface as it slows down in water.

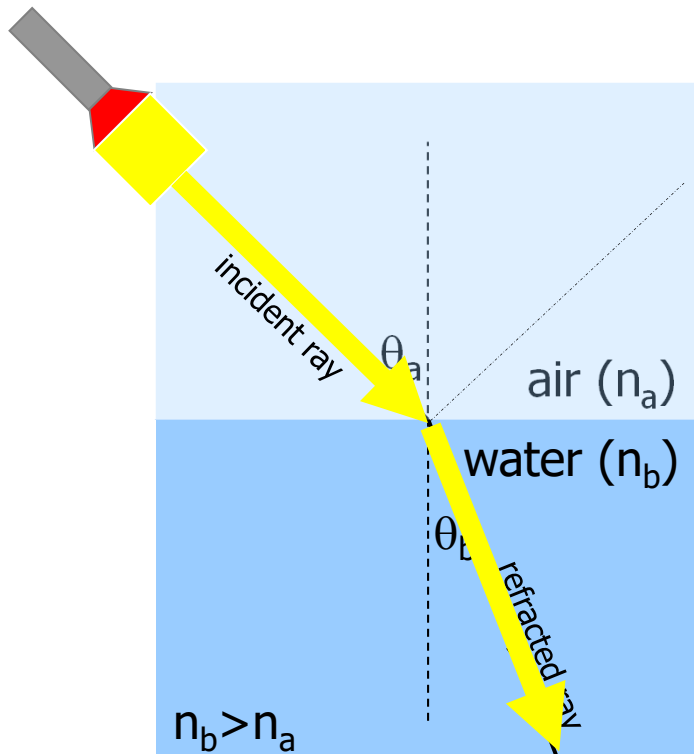

$$(1) \sin(\theta_a) = (1.33) \sin(\theta_b)$$

$$\theta_a > \theta_b$$

$$n_a \sin(\theta_a) = n_b \sin(\theta_b)$$

Light passing from water ( $n \approx 1.33$ ) into air ( $n \approx 1$ ).

Light “bends” away from the normal to the surface as it speeds up in air.

$$(1.33) \sin(\theta_a) = (1) \sin(\theta_b)$$

$$\theta_a < \theta_b$$

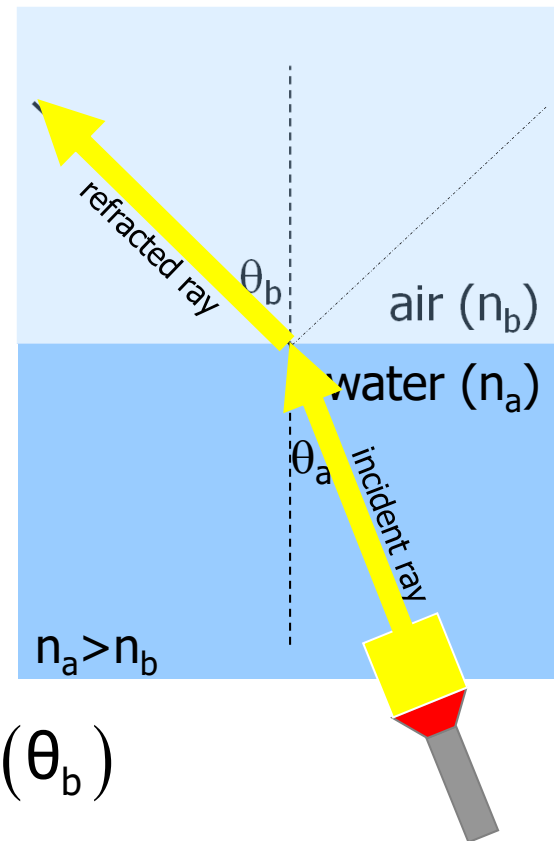

$$n_a \sin(\theta_a) = n_b \sin(\theta_b)$$

**Snell's law:**

$$n_a \sin(\theta_a) = n_b \sin(\theta_b) .$$

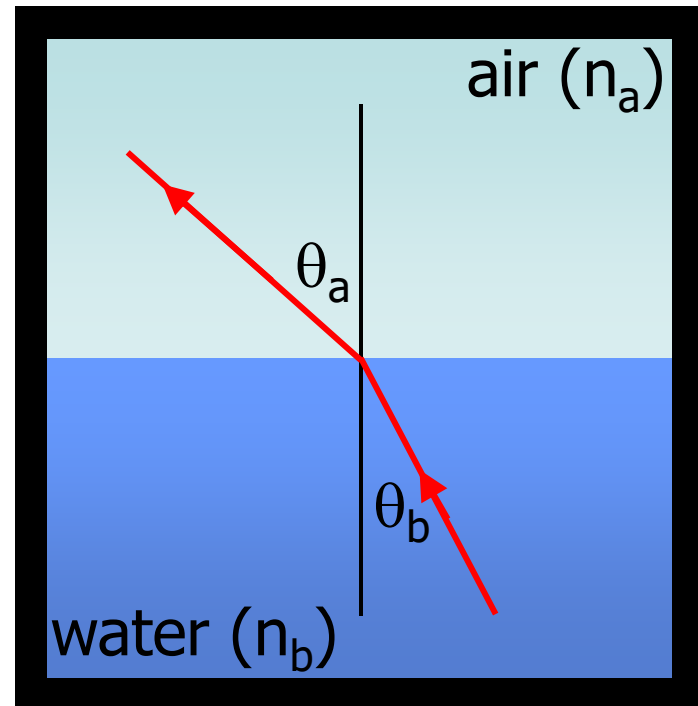
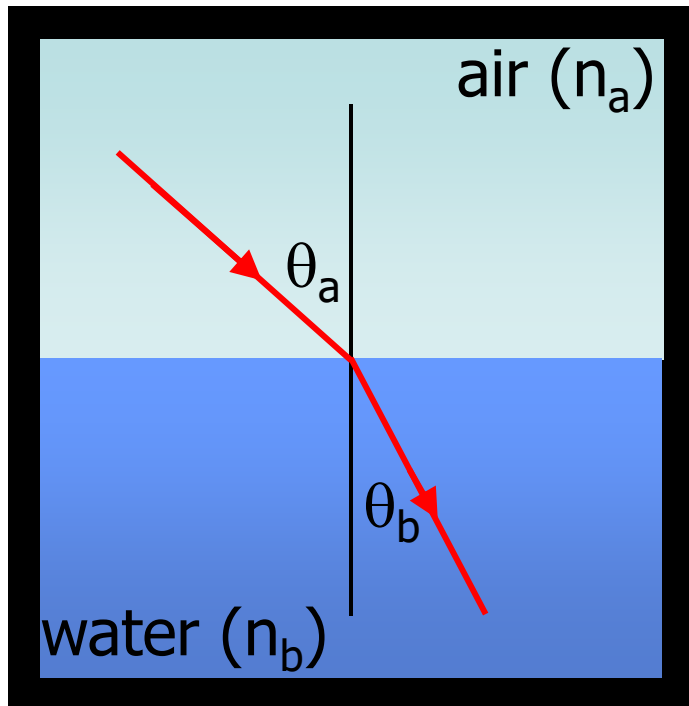

You are free to choose which is "a" and which is "b."

$\theta$  is the angle the ray makes with the normal!



Example: a  $45^\circ$ - $45^\circ$ - $90^\circ$  glass ( $n=1.50$ ) prism is surrounded by water ( $n=1.33$ ). Light is incident at a  $23^\circ$  angle, as shown in the diagram. What angle does the light make when it exits the prism?

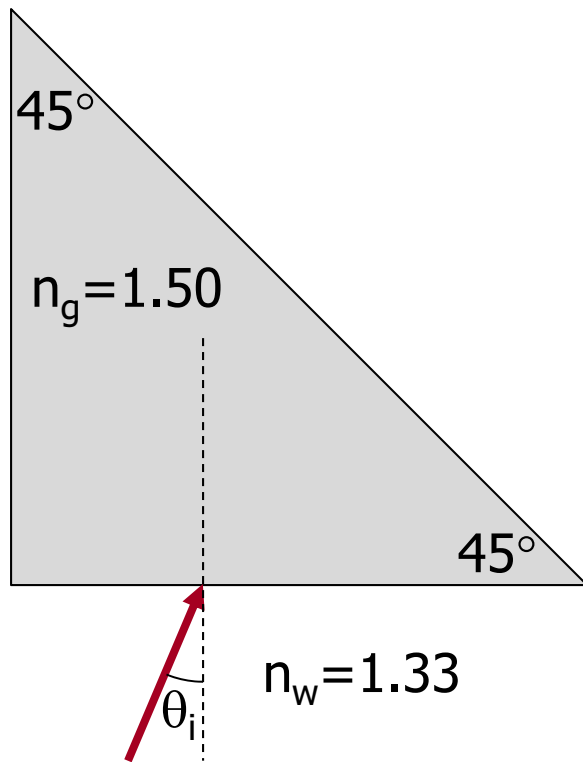

Example: a  $45^\circ$ - $45^\circ$ - $90^\circ$  glass ( $n=1.50$ ) prism is surrounded by water ( $n=1.33$ ). Light is incident at a  $23^\circ$  angle, as shown in the diagram. What angle does the light make when it exits the prism?

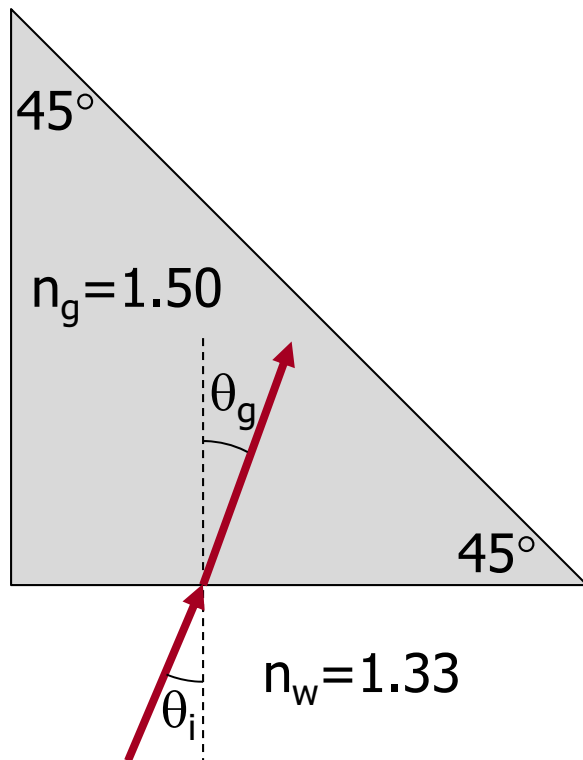

$$1.33 \sin \theta_i = 1.50 \sin \theta_g$$

$$\sin \theta_g = \frac{1.33}{1.50} \sin 23^\circ$$

$$\theta_g = 20.27^\circ \quad \text{keep an extra digit to reduce roundoff error}$$

Example: a  $45^\circ$ - $45^\circ$ - $90^\circ$  glass ( $n=1.50$ ) prism is surrounded by water ( $n=1.33$ ). Light is incident at a  $23^\circ$  angle, as shown in the diagram. What angle does the light make when it exits the prism?

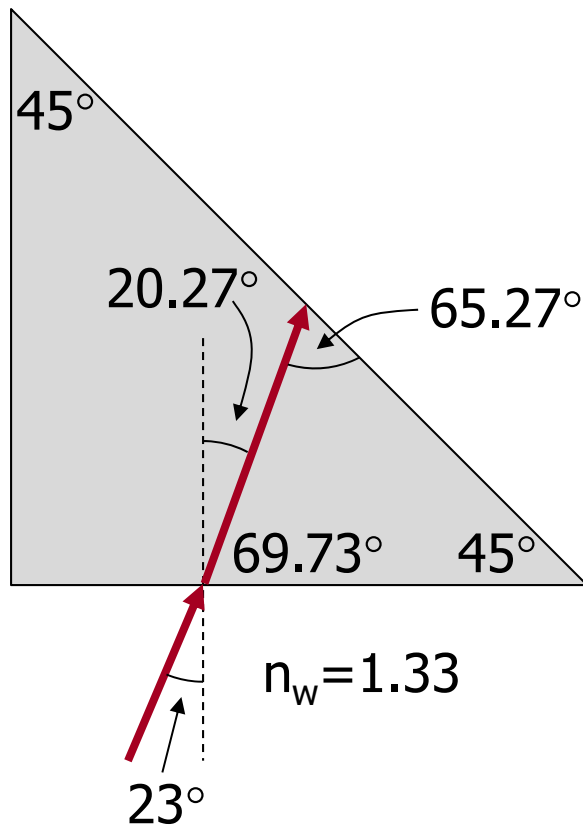

Trig...

$$90^\circ - 20.27^\circ = 69.73^\circ$$

$$180^\circ - 69.73^\circ - 45^\circ = 65.27^\circ$$

$$90^\circ - 65.27^\circ = 24.73^\circ$$

There are a variety of ways to get this.

Example: a  $45^\circ$ - $45^\circ$ - $90^\circ$  glass ( $n=1.50$ ) prism is surrounded by water ( $n=1.33$ ). Light is incident at a  $23^\circ$  angle, as shown in the diagram. What angle does the light make when it exits the prism?

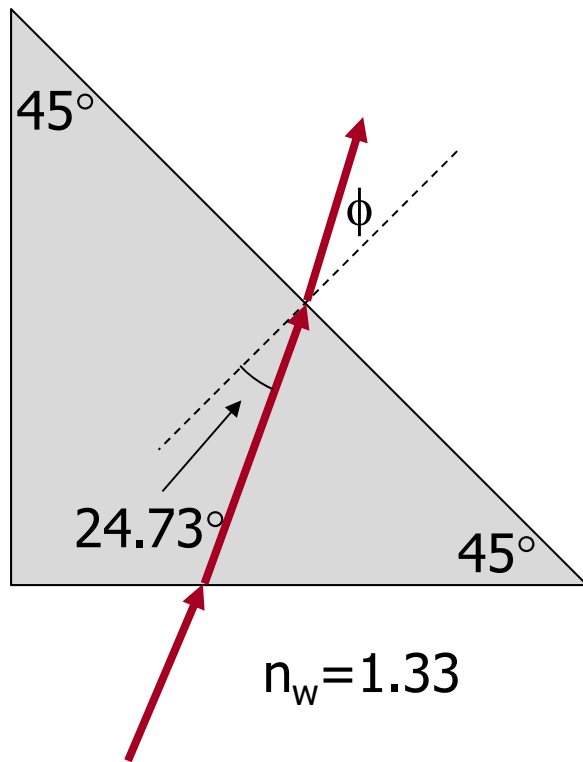

Example: a  $45^\circ$ - $45^\circ$ - $90^\circ$  glass ( $n=1.50$ ) prism is surrounded by water ( $n=1.33$ ). Light is incident at a  $23^\circ$  angle, as shown in the diagram. What angle does the light make when it exits the prism?

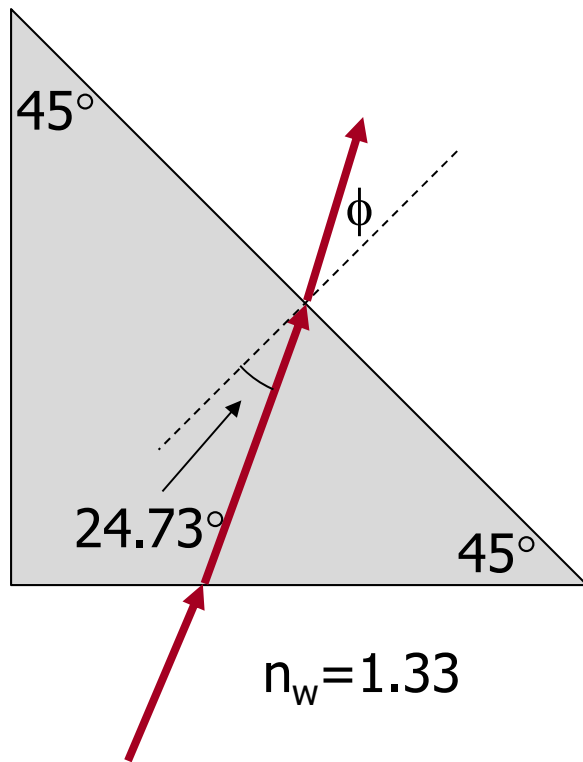

$$1.50 \sin 24.73^\circ = 1.33 \sin \phi$$

$$\sin \phi = \frac{1.50}{1.33} \sin 24.73^\circ$$

$$\phi = 28.2^\circ$$

## Today's agenda:

### Introduction to Light.

You must develop a general understanding of what light is and how it behaves.

### Reflection and Refraction (Snell's Law).

You must be able to determine the path of light rays using the laws of reflection and refraction.

### **Total Internal Reflection and Fiber Optics.**

You must be able to determine the conditions under which total internal reflection occurs, and apply total internal reflection to fiber optic and similar materials.

### Dispersion.

You must understand that the index of refraction of a material is wavelength-dependent.

## Total Internal Reflection; Fiber Optics

$$n_1 \sin(\theta_1) = n_2 \sin(\theta_2)$$

$$\sin(\theta_1) = \frac{n_2}{n_1} \sin(\theta_2)$$

### Suppose $n_2 < n_1$

- largest possible value of  $\sin(\theta_2)$  is 1 (when  $\theta_2 = 90^\circ$ )
- therefore, largest possible value of  $\sin(\theta_1)$  is

$$\sin(\theta_{1,\max}) = \sin(\theta_c) = \frac{n_2}{n_1}.$$

For  $\theta_1$  larger than  $\theta_c$ , Snell's Law cannot be satisfied!

- for  $\theta_1 > \theta_c$ : no refracted ray, light is **totally reflected**
- $\theta_c$  is called the critical angle of total internal reflection

$$\theta_1 < \theta_c$$

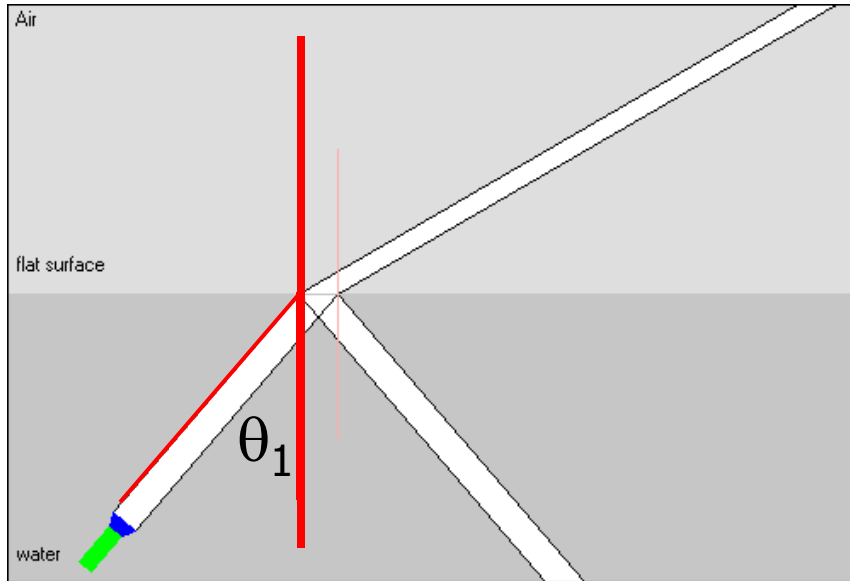

$$\theta_1 \text{ close to } \theta_c$$

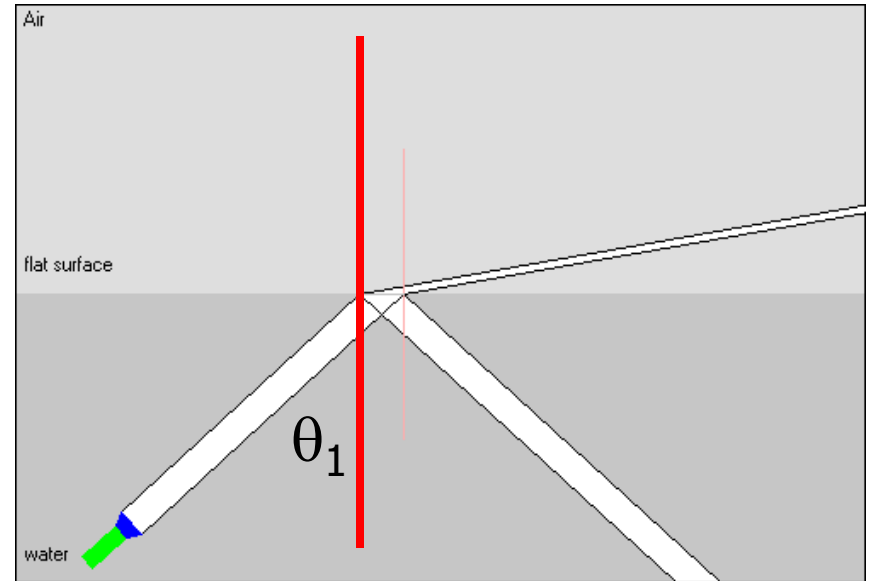

$$\theta_1 > \theta_c$$

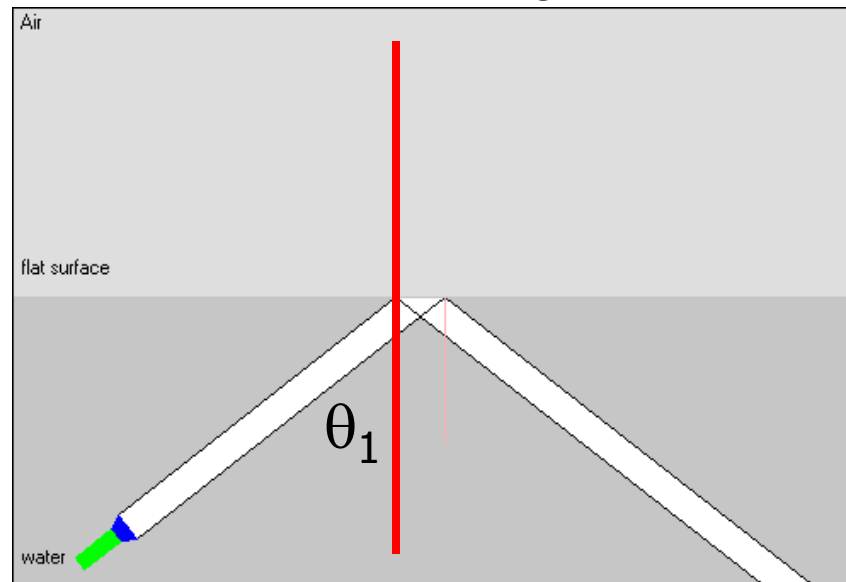



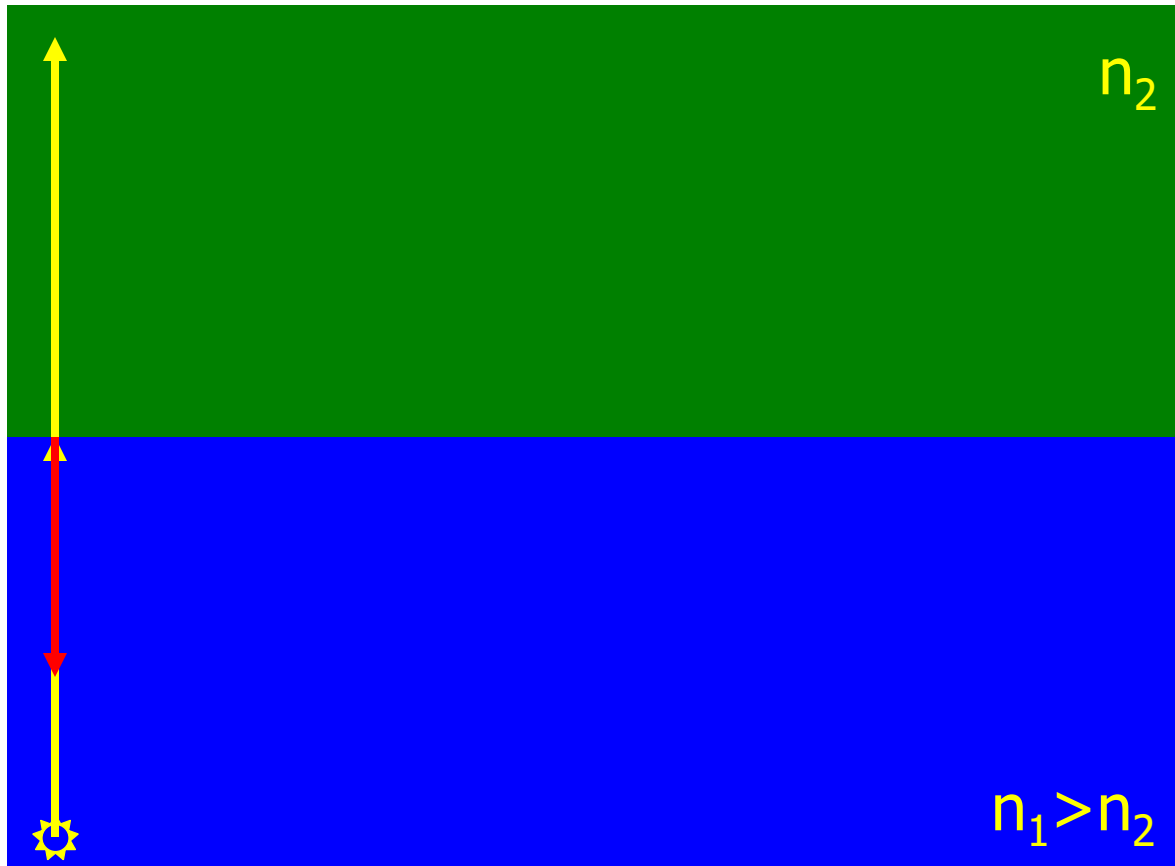

Ray incident normal to surface is not "bent." Some is reflected, some is transmitted.

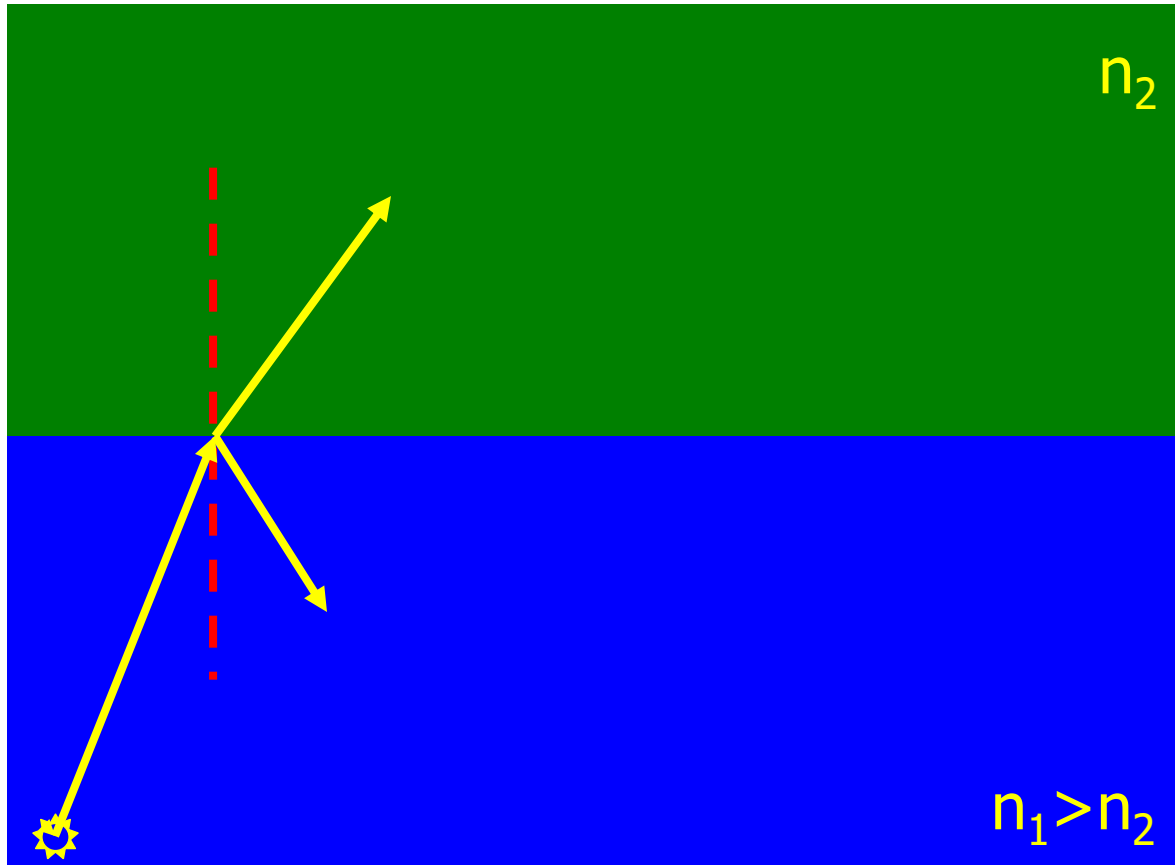

Increasing angle of incidence...

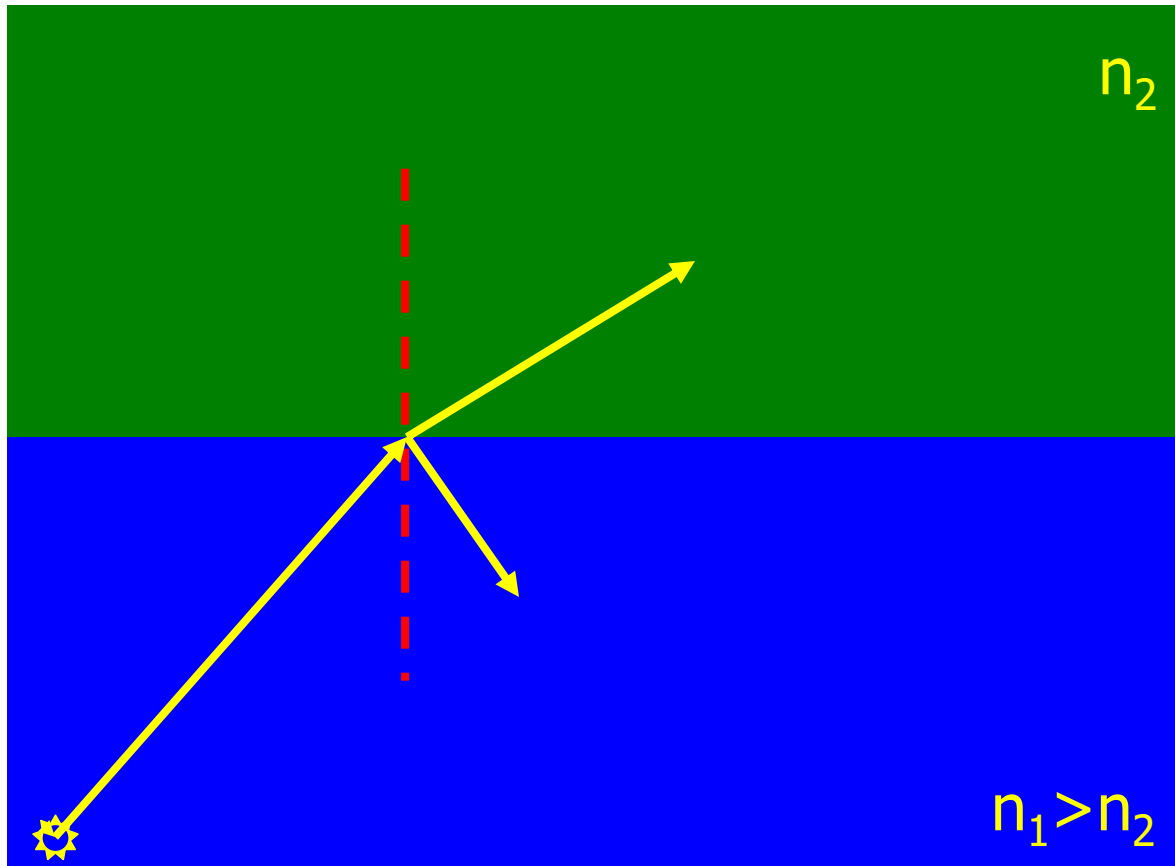

Increasing angle of incidence...more...

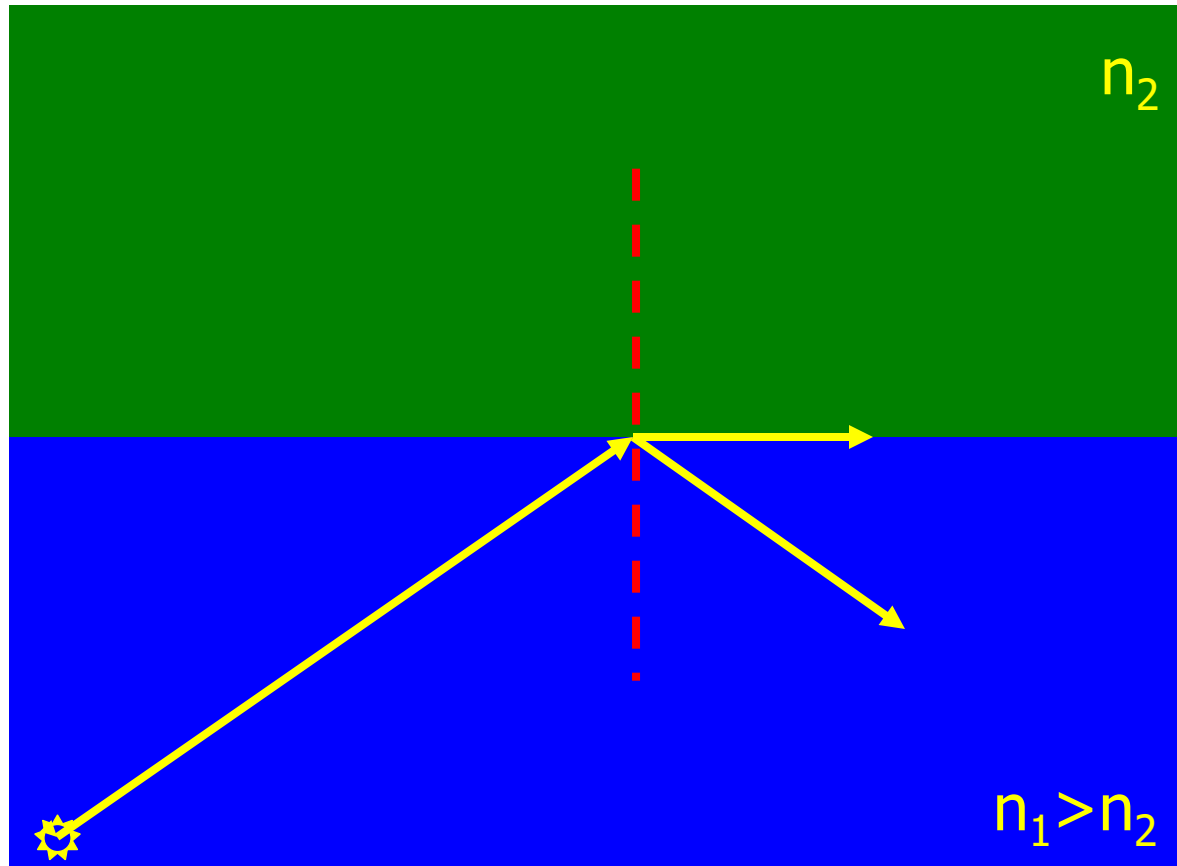

Increasing angle of incidence...more...critical angle reached...  
some of incident energy is reflected, some is "transmitted  
along the boundary layer.

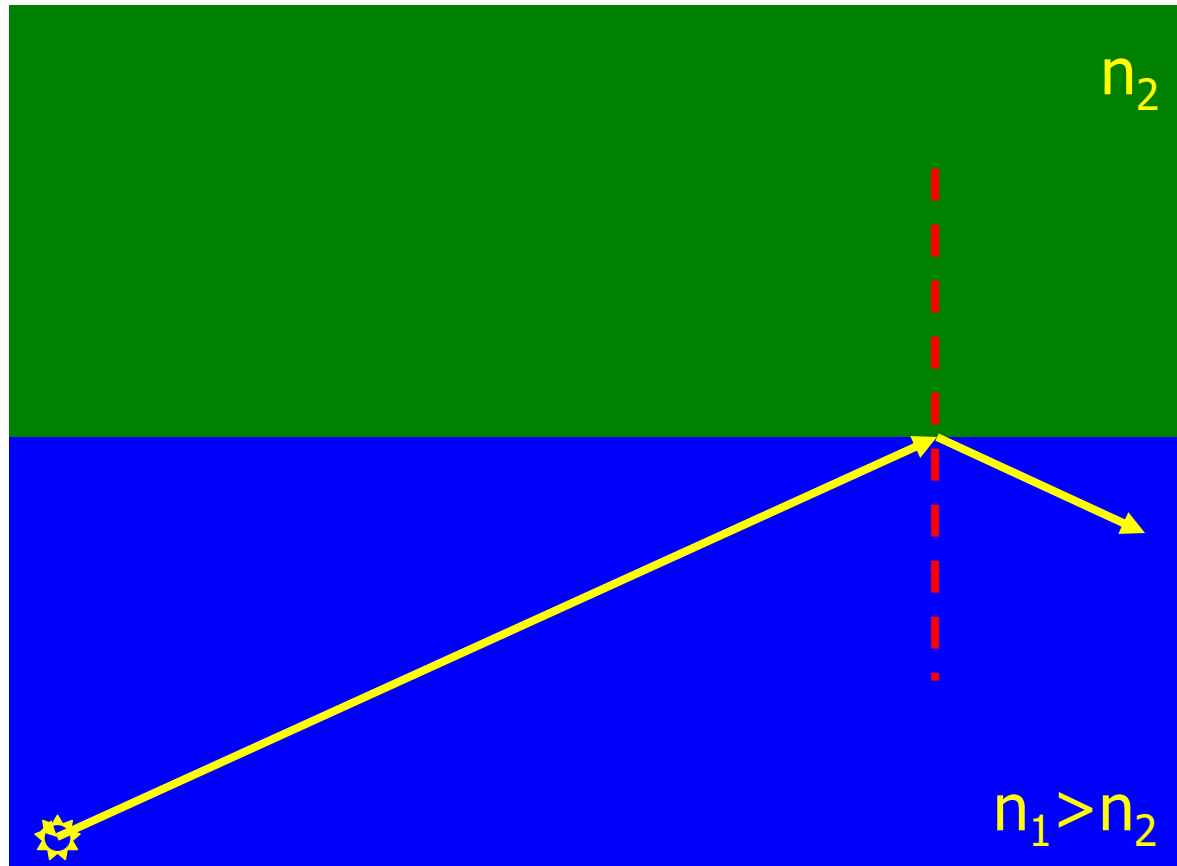

Light incident at any angle beyond  $\theta_C$  is totally internally reflected.

application: fiber optics



<http://laser.physics.sunysb.edu/~wise/wise187/janfeb2001/reports/andrea/report.html>

Example: determine the incident angle  $\theta_i$  for which light strikes the inner surface of a fiber optic cable at the critical angle.

Light is incident at an angle  $\theta_i$  on a transparent fiber.

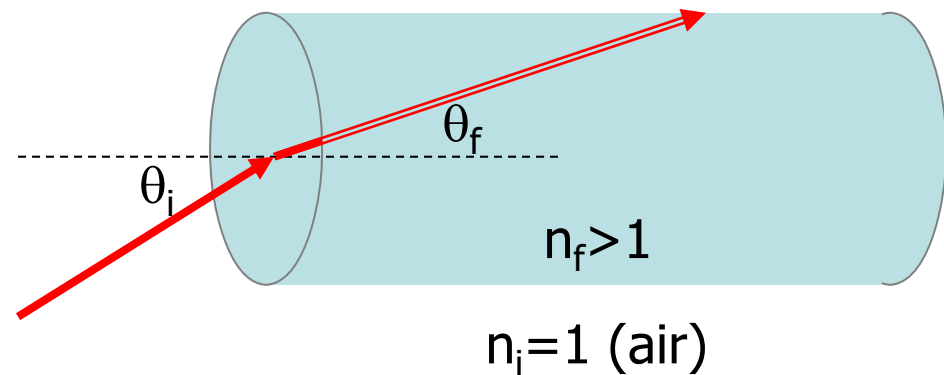

The light refracts at an angle  $\theta_f$ .

$$n_i \sin(\theta_i) = n_f \sin(\theta_f)$$

$$\sin(\theta_i) = n_f \sin(\theta_f)$$

Light strikes the fiber wall at an angle of  $90^\circ - \theta_f$  normal to the surface.

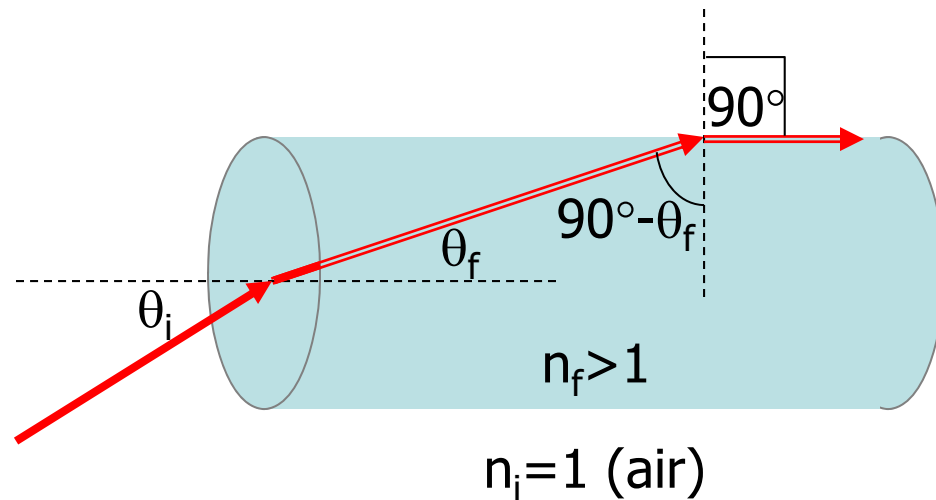

At the critical angle, instead of exiting the fiber, the refracted light travels along the fiber-air boundary. In this case,  $90^\circ - \theta_f$  **is** the critical angle.

$$n_f \sin(90 - \theta_f) = n_f \sin(\theta_c) = n_a \sin(90) = 1$$

$$\sin(90 - \theta_f) = \frac{1}{n_f}$$

Solve the above for  $\theta_f$  and use  $\sin(\theta_i) = n_f \sin(\theta_f)$  to solve for  $\theta_i$ .



Numerical example:  
what  $\theta_i$  will result in the  
critical angle if  $n_f=1.4$ ?

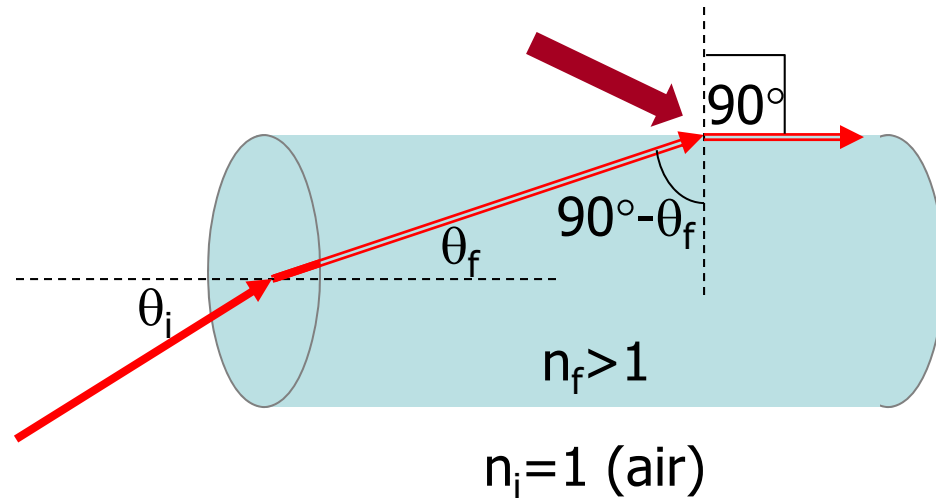

Begin the analysis at the fiber-into-air interface:

$$(1.4) \sin(90 - \theta_f) = (1) \sin(90)$$

$$\sin(90 - \theta_f) = \frac{1}{1.4}$$

$$90 - \theta_f = 45.58^\circ$$

keep an extra digit to  
reduce roundoff error

$$\theta_f = 44.41^\circ$$

Numerical example:  
what  $\theta_i$  will result in the  
critical angle if  $n_f=1.4$ ?

$$\theta_f = 44.41^\circ$$

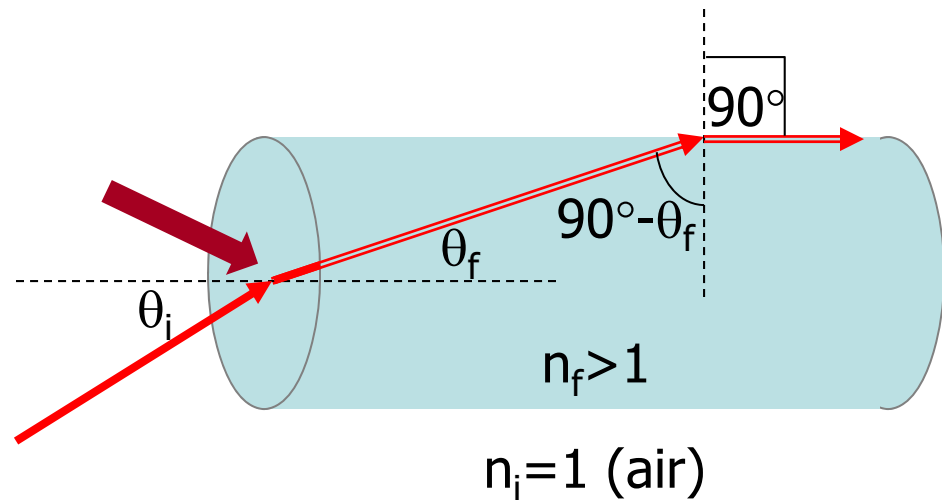

Next consider the air-into-fiber interface.

$$(1) \sin(\theta_i) = (1.4) \sin(44.41)$$

$$\sin(\theta_i) = 0.980$$

$$\theta_i = 78.5^\circ$$

This is a very large angle of incidence! If you want the incident light to be nearly parallel to the fiber axis, you must surround the fiber with a coating with  $n_{\text{outside}} < n_{\text{coating}} < n_{\text{fiber}}$

application: [swimming underwater](#)

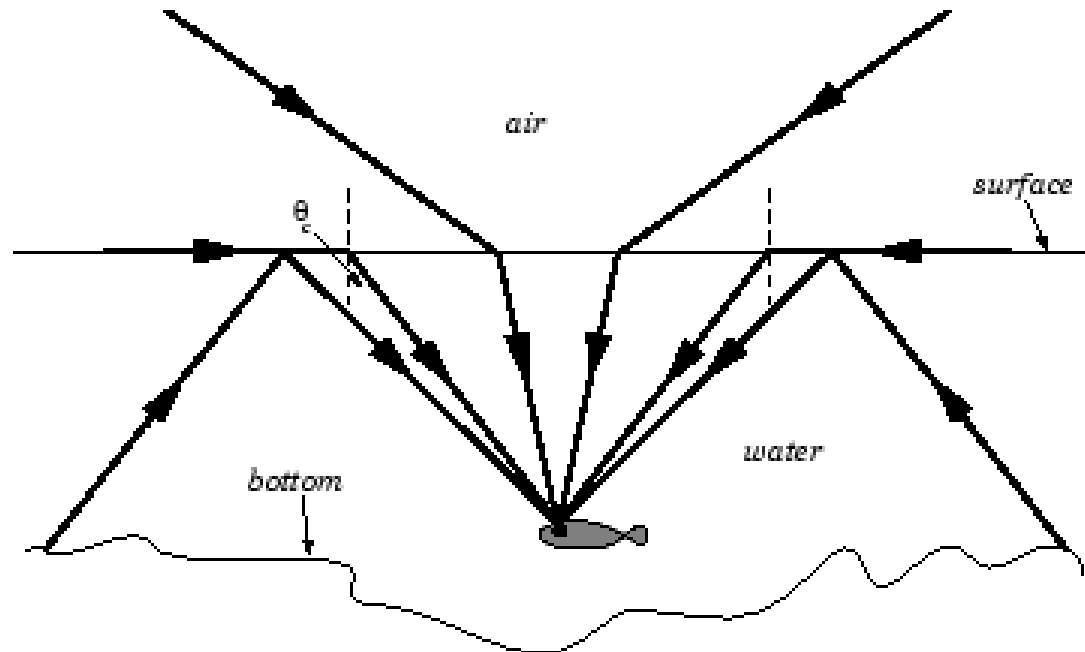

If you are looking up from underwater, if your angle of sight (relative to the normal to the surface) is too large, you see an underwater reflection instead of what's above the water.

application: [perfect mirrors](#)

(used in binoculars)

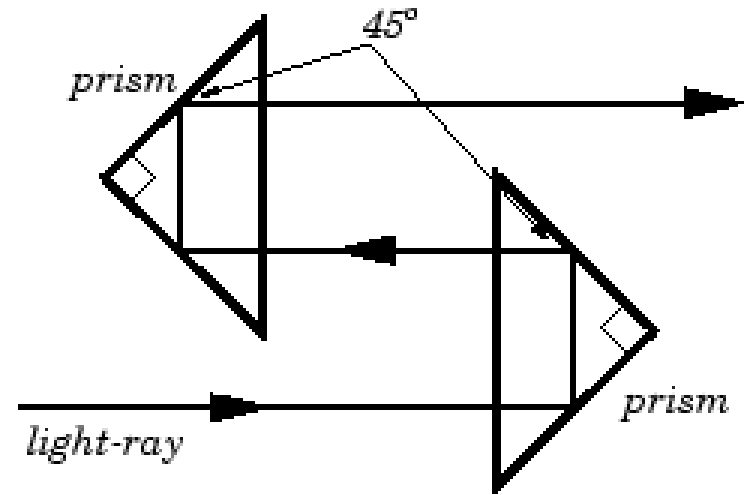

application: [diamonds](#)

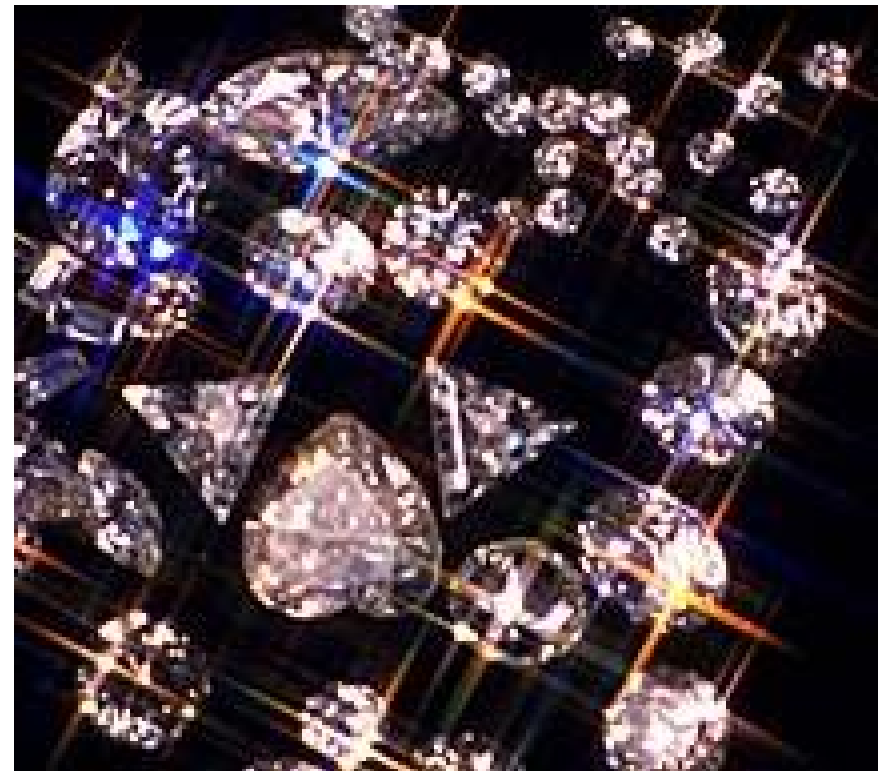

## Today's agenda:

### Introduction to Light.

You must develop a general understanding of what light is and how it behaves.

### Reflection and Refraction (Snell's Law).

You must be able to determine the path of light rays using the laws of reflection and refraction.

### Total Internal Reflection and Fiber Optics.

You must be able to determine the conditions under which total internal reflection occurs, and apply total internal reflection to fiber optic and similar materials.

### **Dispersion.**

You must understand that the index of refraction of a material is wavelength-dependent.

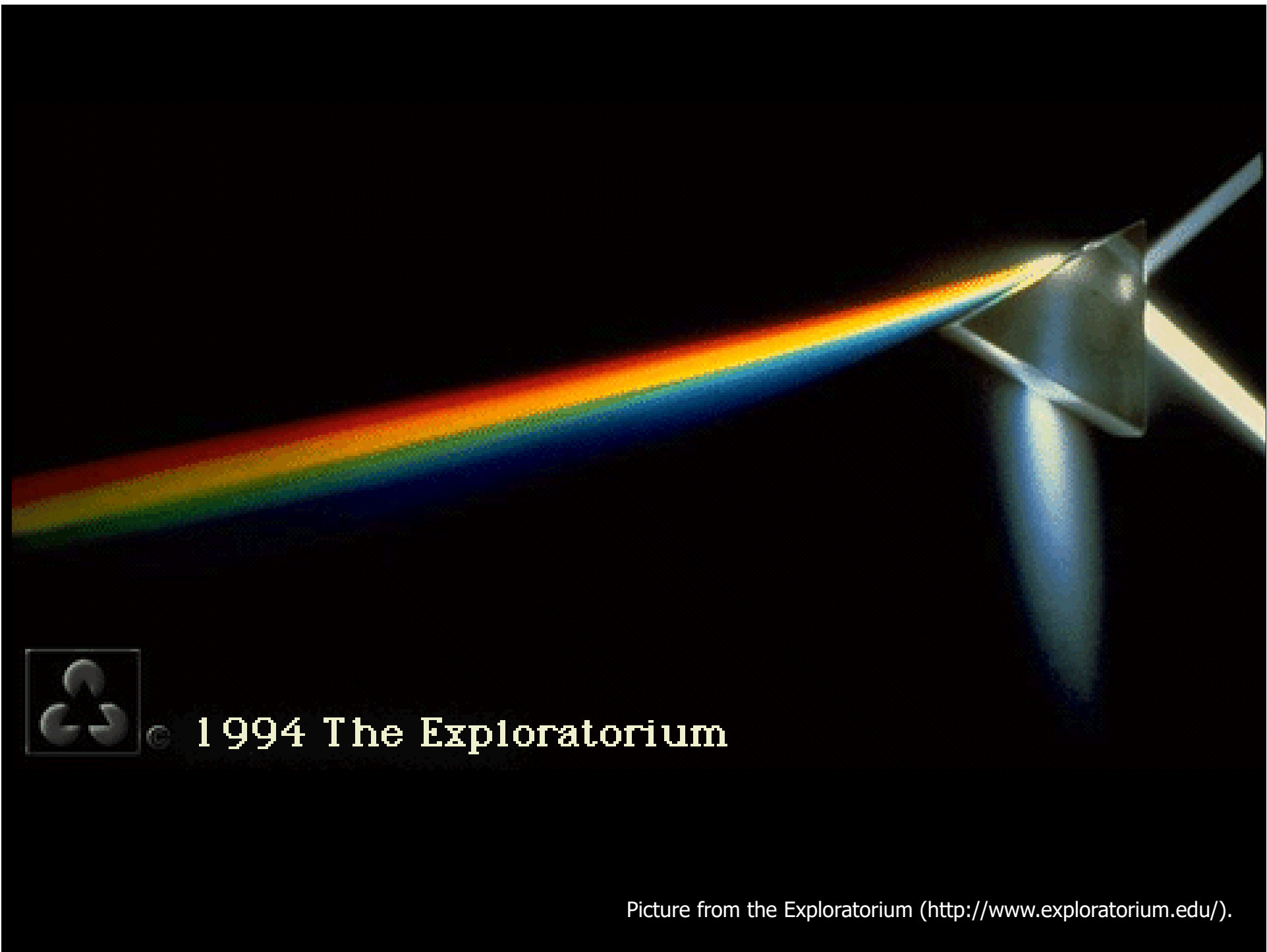

© 1994 The Exploratorium

Picture from the Exploratorium (<http://www.exploratorium.edu/>).

# Dispersion

We've treated index of refraction of a material as if it had a single value for all wavelengths.

In fact, speed of light in a substance depends on wavelength, so the **index of refraction depends on wavelength** (or color).

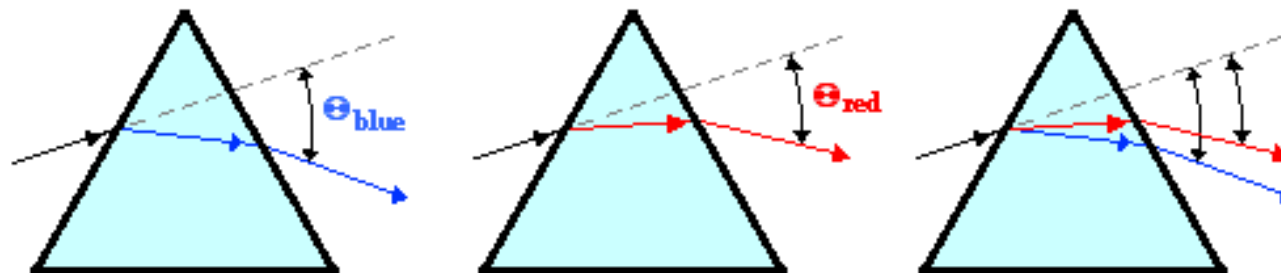

Blue light refracts more than red light due to the difference in wavelength. This causes blue light to deviate from its original path by a greater angle than the red light.

<http://www.physicsclassroom.com/class/refrn/Lesson-4/Dispersion-of-Light-by-Prisms>

When light shines on a surface. The light may be

- Reflected ( $\theta_r = \theta_i$ ),
- Transmitted ( $n_a \sin \theta_a = n_b \sin \theta_b$ , for each surface),
- Absorbed or
- A combination of the above options may occur.

