

Today's agenda:

Resistors in Series and Parallel.

You must be able to calculate currents and voltages in circuit components in series and in parallel.

Kirchoff's Rules.

You must be able to use Kirchoff's Rules to calculate currents and voltages in circuit components that are not simply in series or in parallel.

Resistances in Circuits

Recall from lecture 7:

- two simple ways to connect circuit elements

Series:



Parallel:

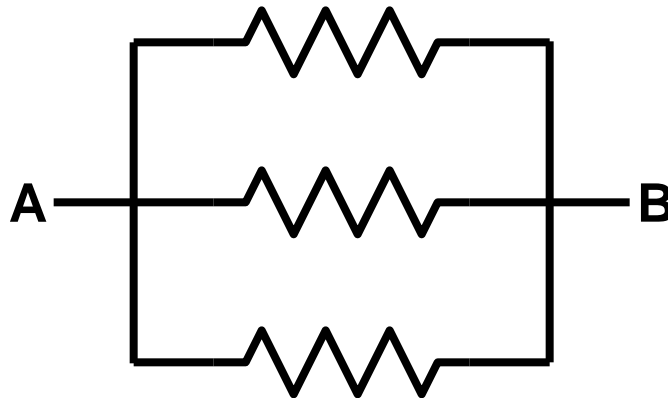

Circuit elements can be connected neither in series nor in parallel.

Identifying series and parallel connections

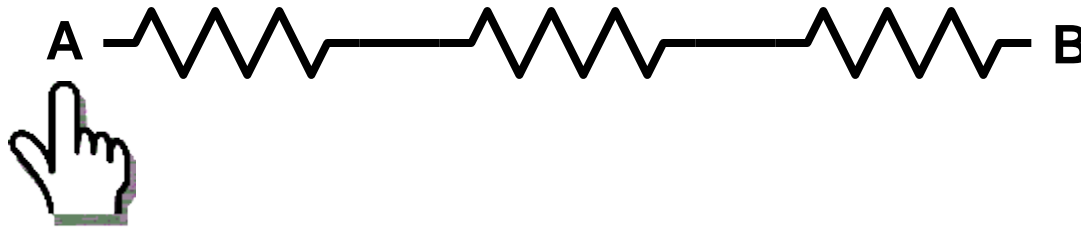

If you can move your finger along the wires from A to B **without passing a junction**, i.e., without ever having a choice of which wire to follow, the components are connected in series.

In contrast:

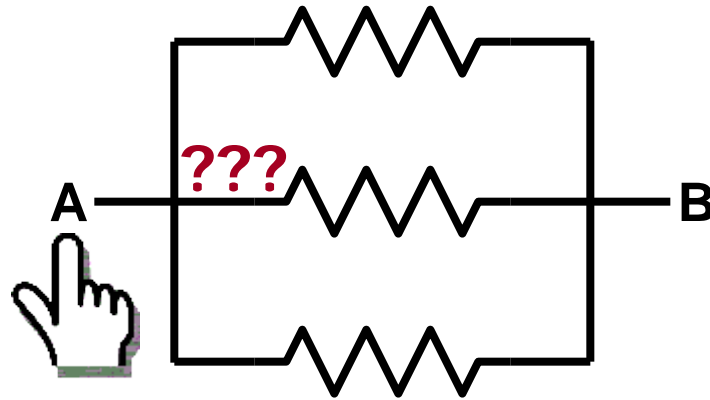

If you ever have a choice of which wire to follow when moving from A to B, the circuit elements are **not** in series.

If each element provides an alternative path between the same points A and B, the elements are in **parallel**.

Circuit elements can be connected neither in series nor in parallel.

Are these resistors in series or parallel?

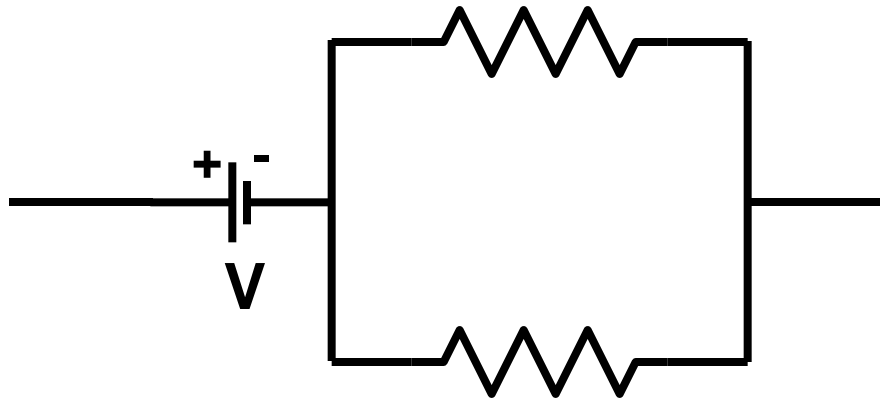

parallel

Not enough information: It matters where you put the source of emf.

Are these resistors in series or parallel?

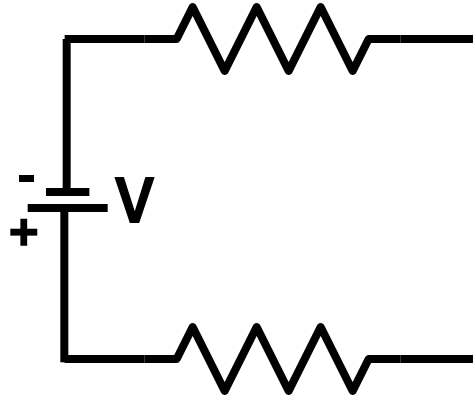

series

It matters where you put the source of emf.

Resistors in series

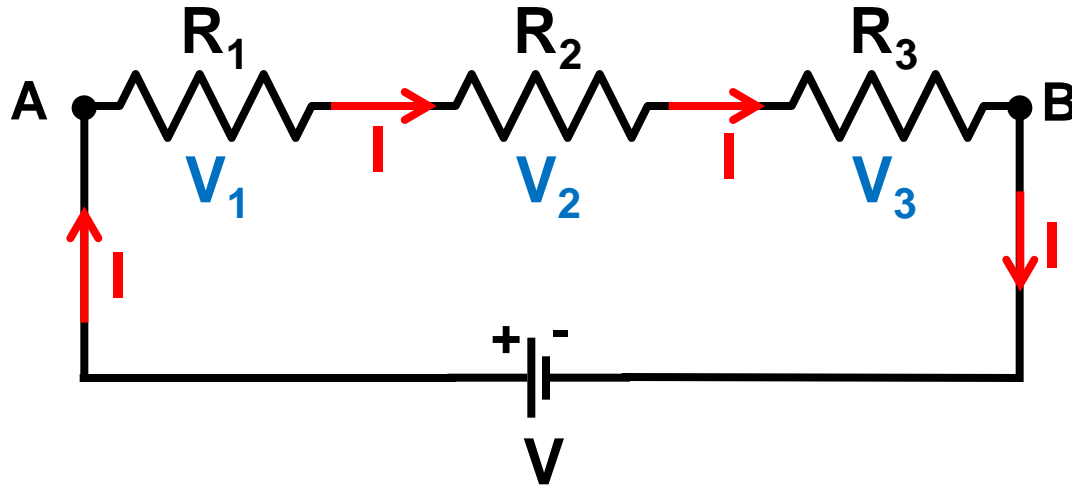

Current: same current flows through all resistors
(conservation of charge: all charge entering the series of resistors at A must leave it at B)

Voltage: voltages in a series add up $V_{AB} = V_1 + V_2 + V_3$
(loop rule, see last lecture, reflecting conservation of energy)

Equivalent resistance

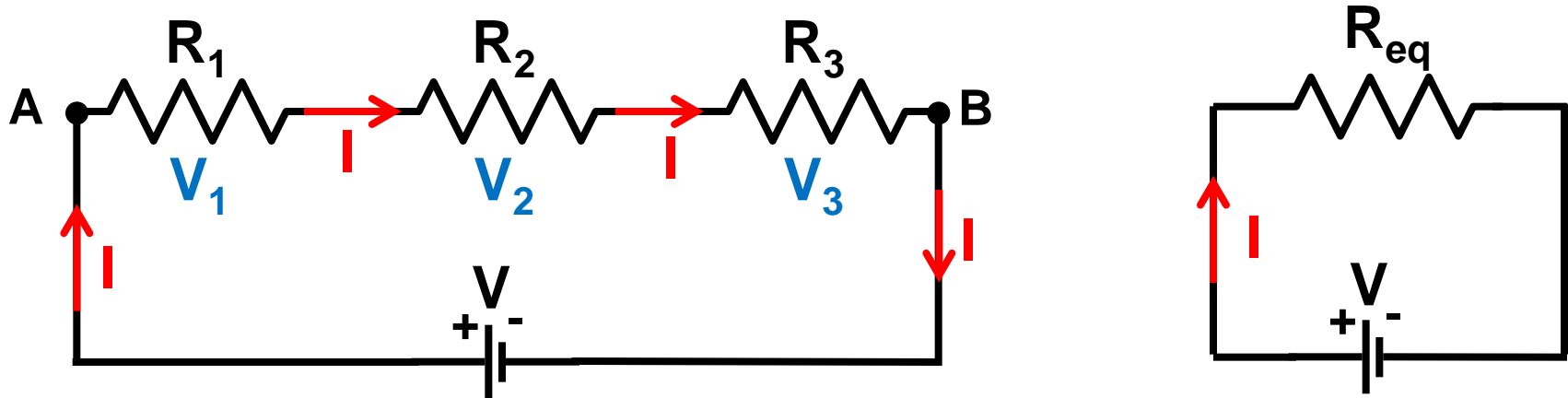

Replace the series combination by a single “equivalent” resistor (producing same total voltage for same current)

$$V = V_1 + V_2 + V_3$$

$$V = IR_1 + IR_2 + IR_3$$

$$V = IR_{eq}$$

$$IR_1 + IR_2 + IR_3 = IR_{eq}$$

$$R_1 + R_2 + R_3 = R_{eq}$$

Generalize this to any number of resistors:

$$R_{\text{eq}} = \sum_i R_i$$

- resistances in series add up!

Note: for resistors in series, R_{eq} is always greater than any of the R_i .

Resistors in parallel

Current:

- current I splits into currents I_1, I_2, I_3
 $I = I_1 + I_2 + I_3$ (conservation of charge)

Voltage:

- Voltage drops across all three resistors are identical
 $V_{AB} = V_1 = V_2 = V_3$ (conservation of energy)

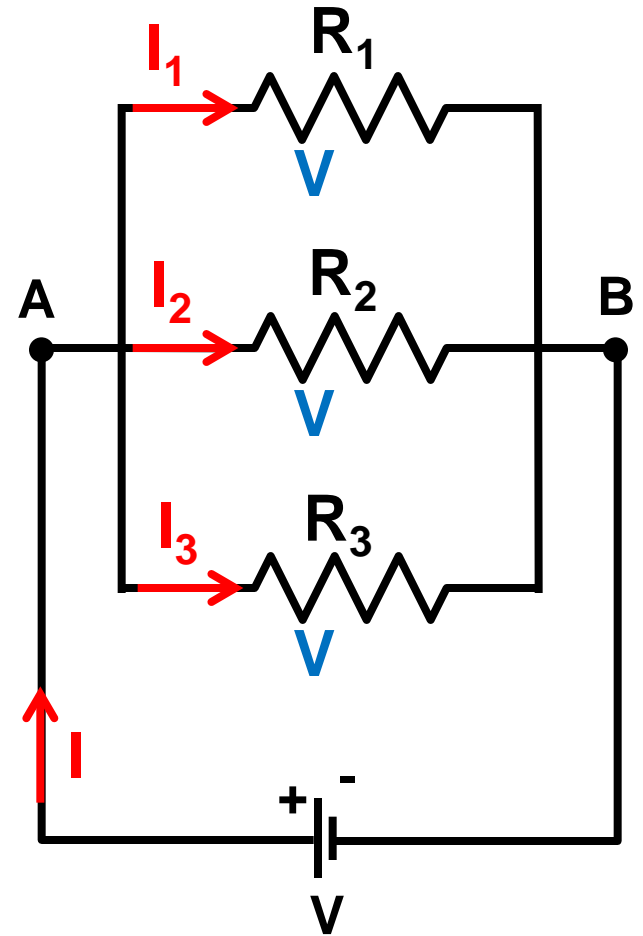

Equivalent resistance

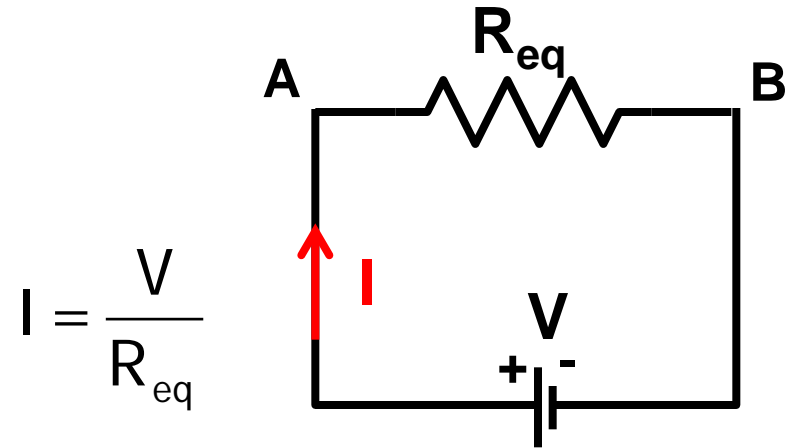
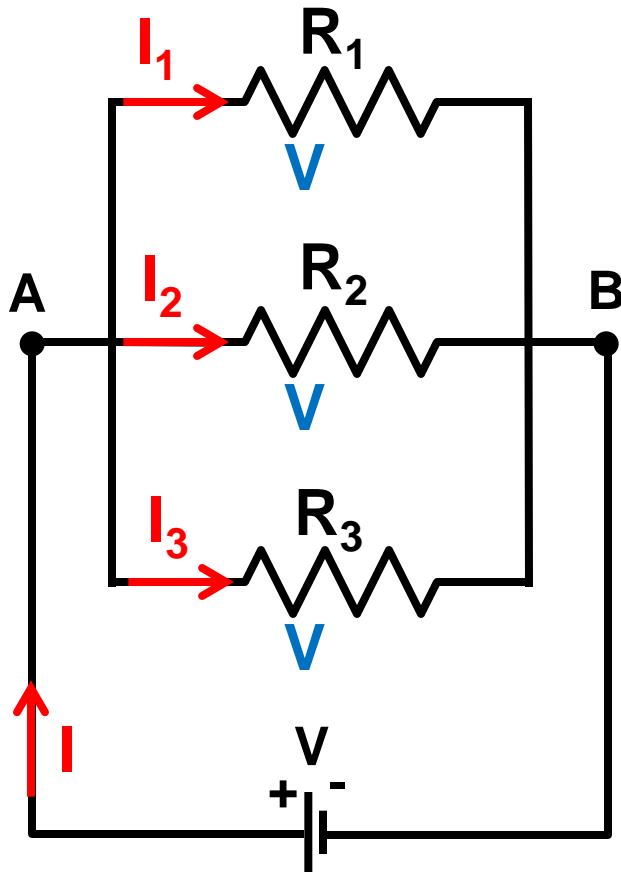

$$I = \frac{V}{R_{eq}}$$

Replace parallel combination by single equivalent resistor

$$\frac{V}{R_{eq}} = \frac{V}{R_1} + \frac{V}{R_2} + \frac{V}{R_3}$$

$$I = I_1 + I_2 + I_3$$

$$I = \frac{V}{R_1} + \frac{V}{R_2} + \frac{V}{R_3}$$

Dividing both sides by V gives

$$\frac{1}{R_{eq}} = \frac{1}{R_1} + \frac{1}{R_2} + \frac{1}{R_3}$$

Generalize this to any number of resistors:

$$\frac{1}{R_{\text{eq}}} = \sum_i \frac{1}{R_i}$$

- for resistors in parallel, the inverse resistances add

Note: for resistors in parallel, R_{eq} is always less than any of the R_i .

Summary:

Series



same I , V 's add

$$R_{\text{eq}} = \sum_i R_i$$

Parallel

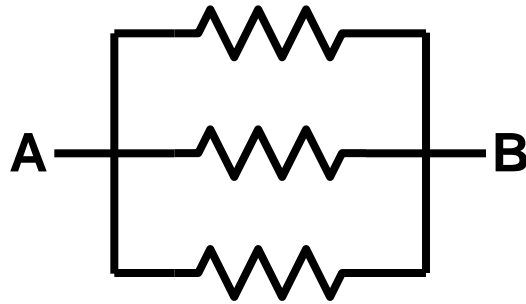

same V , I 's add

$$\frac{1}{R_{\text{eq}}} = \sum_i \frac{1}{R_i}$$

Example: calculate the equivalent resistance of the resistor "ladder" shown. All resistors have the same resistance R .

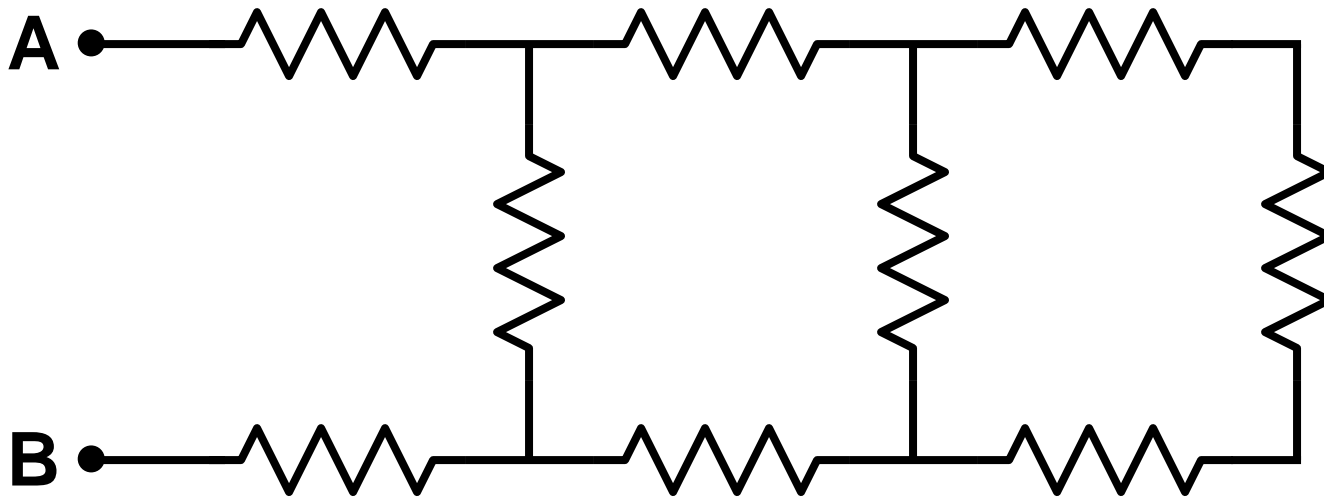

Let's discuss the strategy!

Where to start?

Series

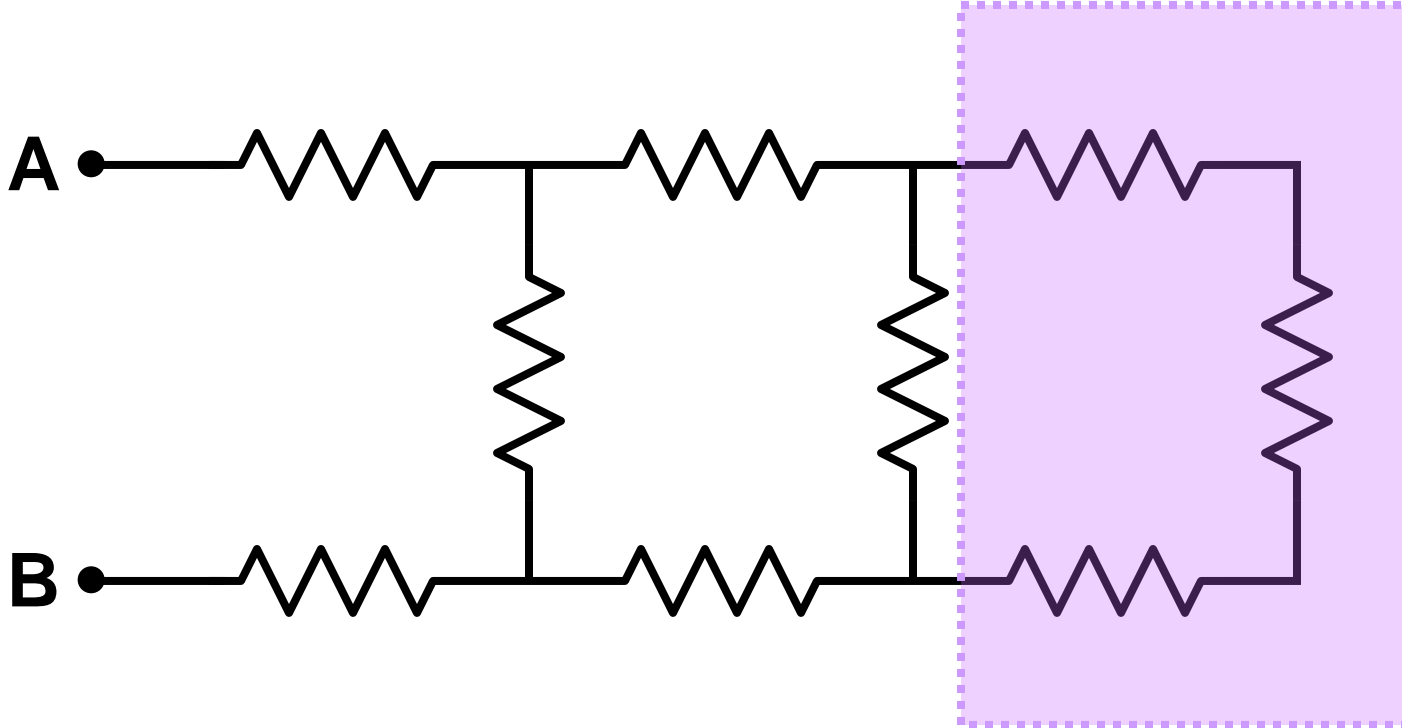

- new **color** indicates an **equivalent resistor** made up of several original ones

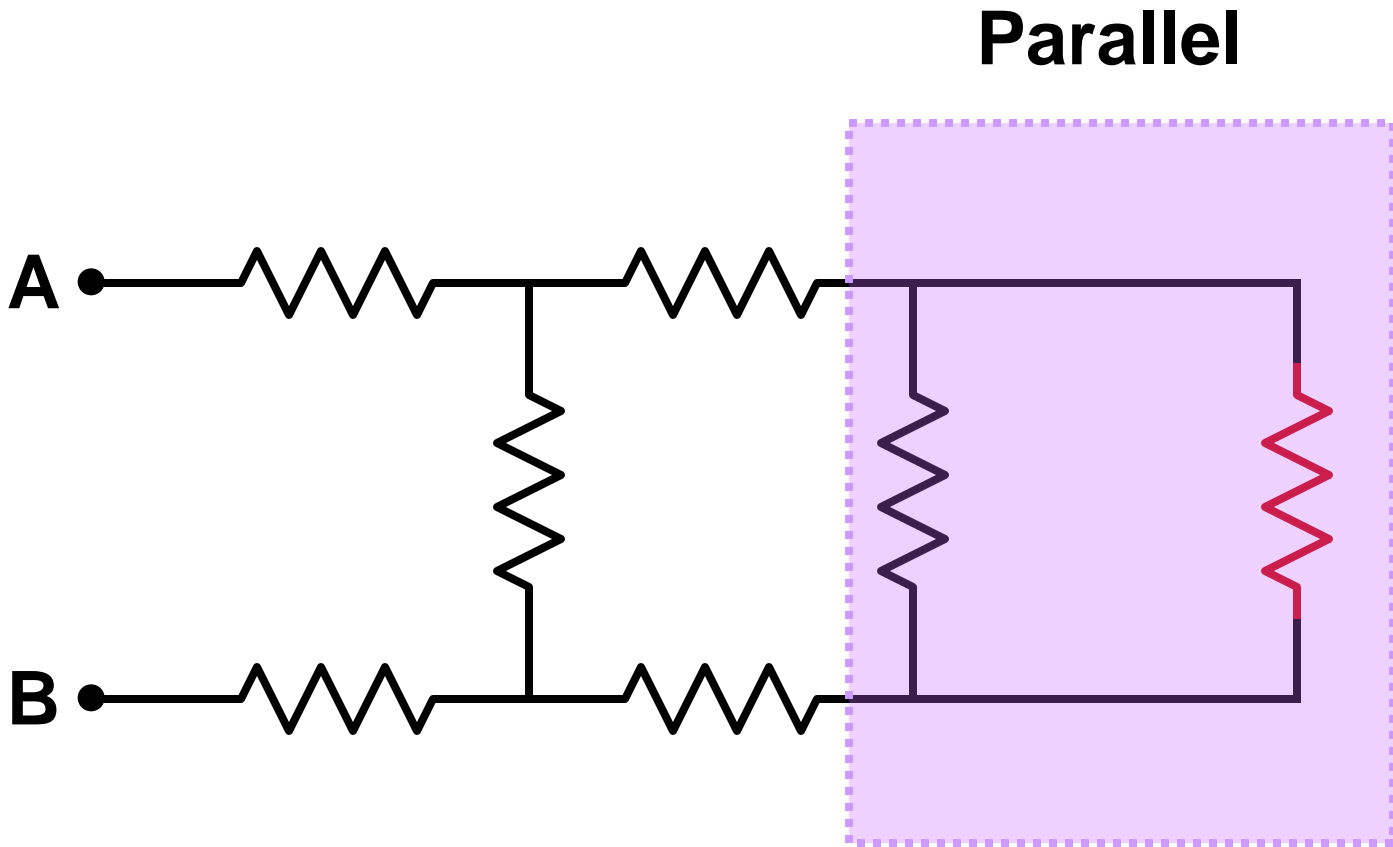

Series

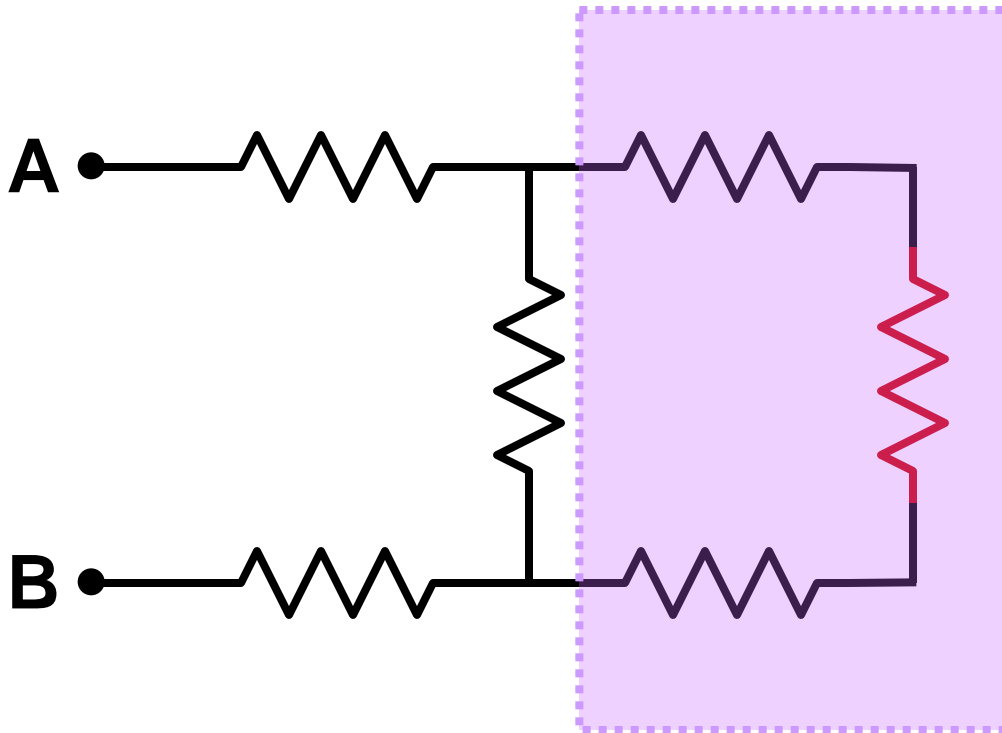

Parallel

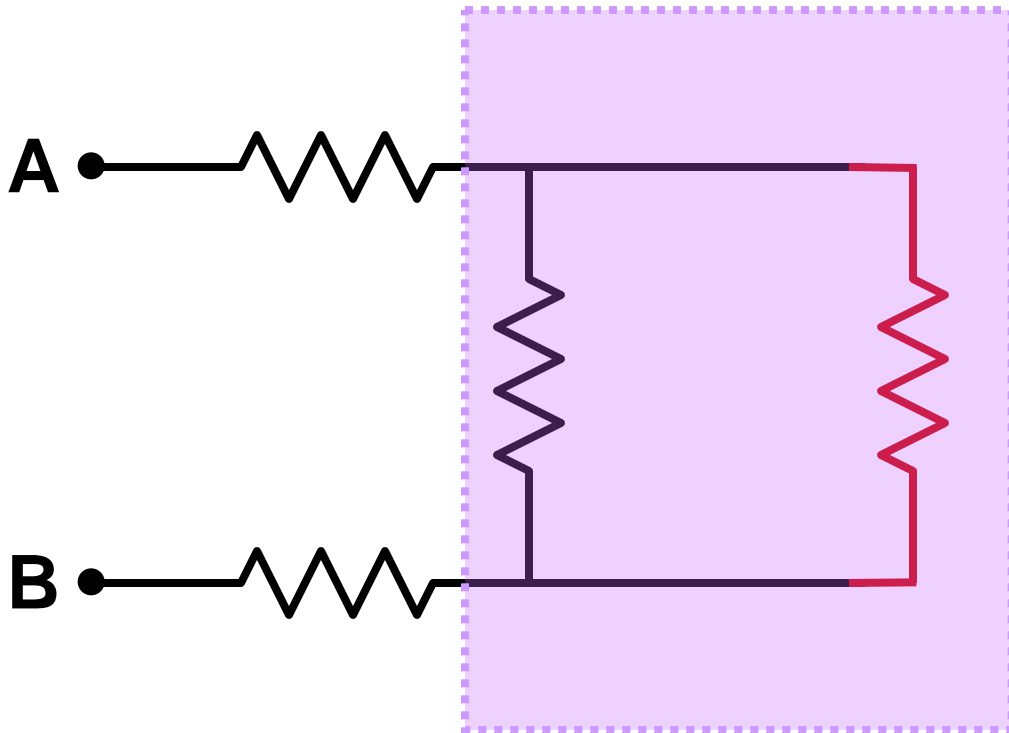

Series

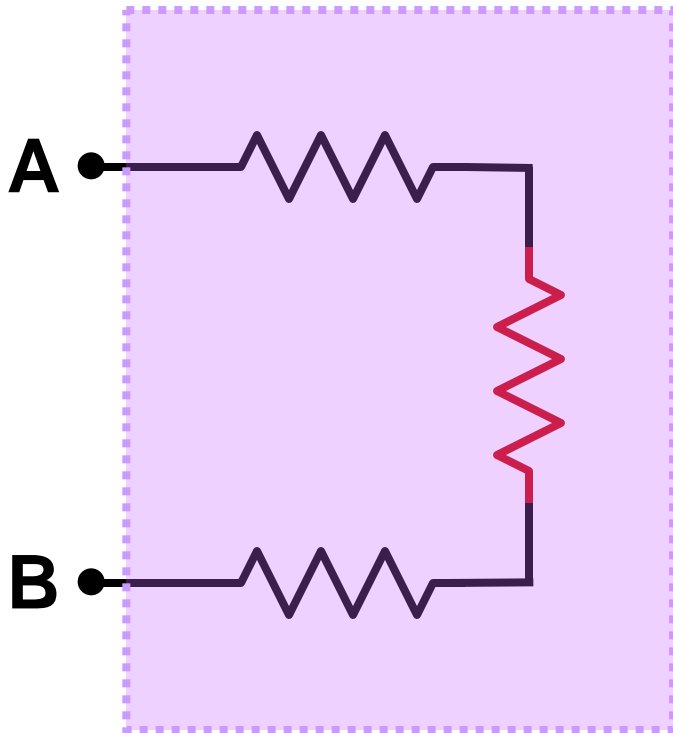

All done!

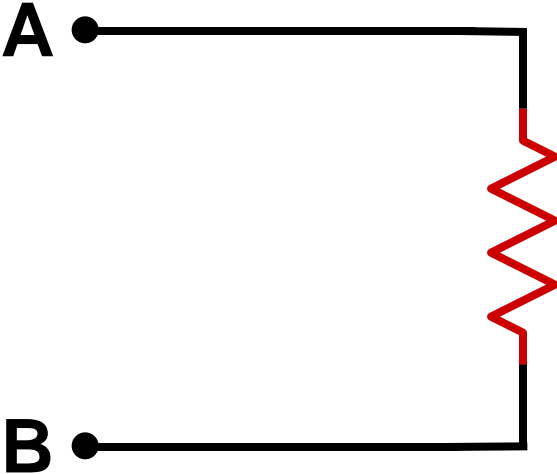

Example: For the circuit below, calculate the current drawn from the battery and the current in the $6\ \Omega$ resistor.

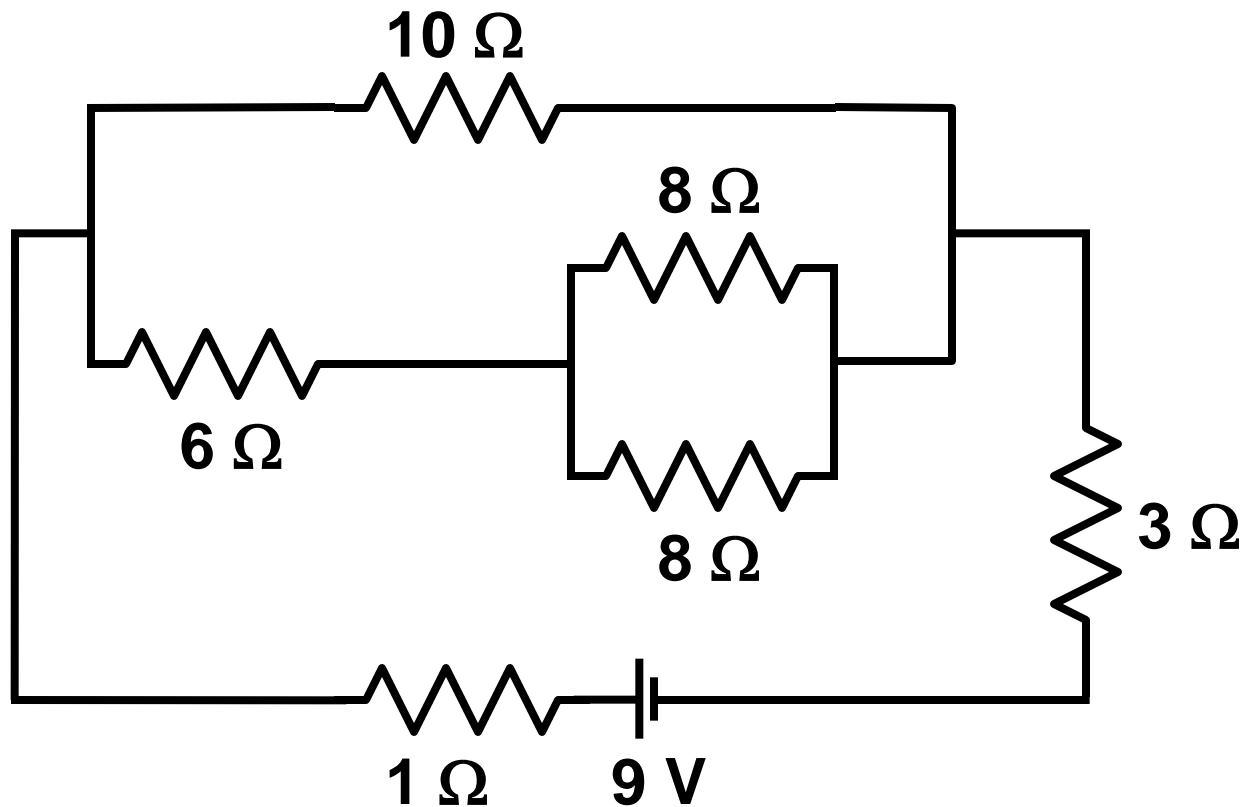

Work the example at the blackboard in lecture.

Strategy: Identify "bite-sized chunks"

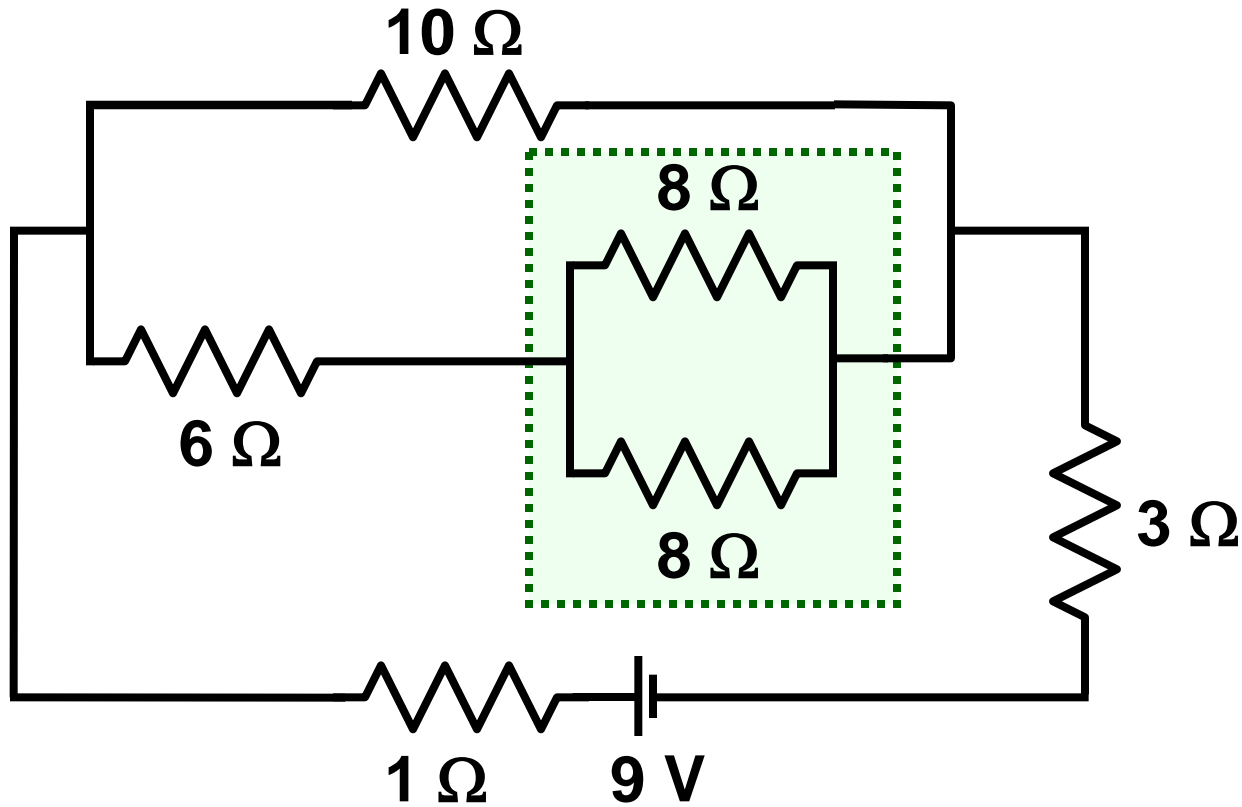

Replace parallel combination (green) by its equivalent.

Any more "bite-sized chunks?"

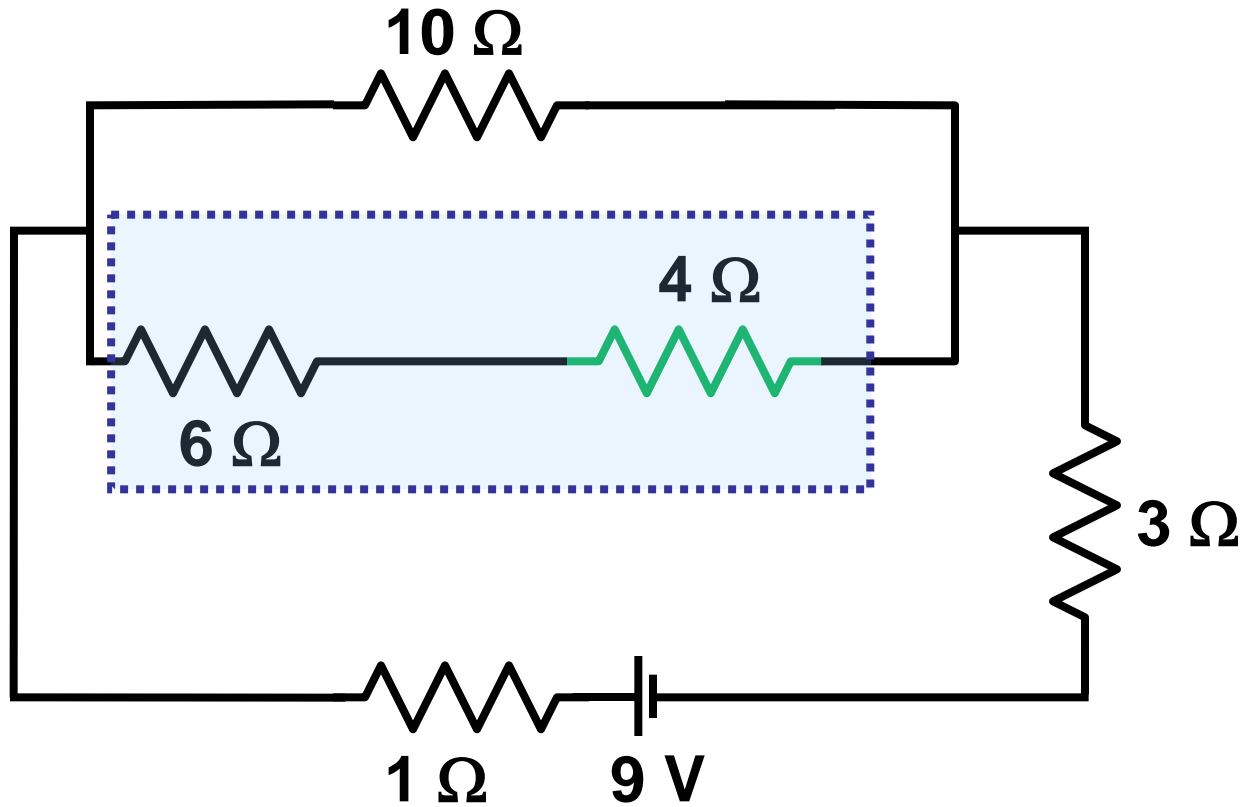

Replace the series combination (blue box) by its equivalent.

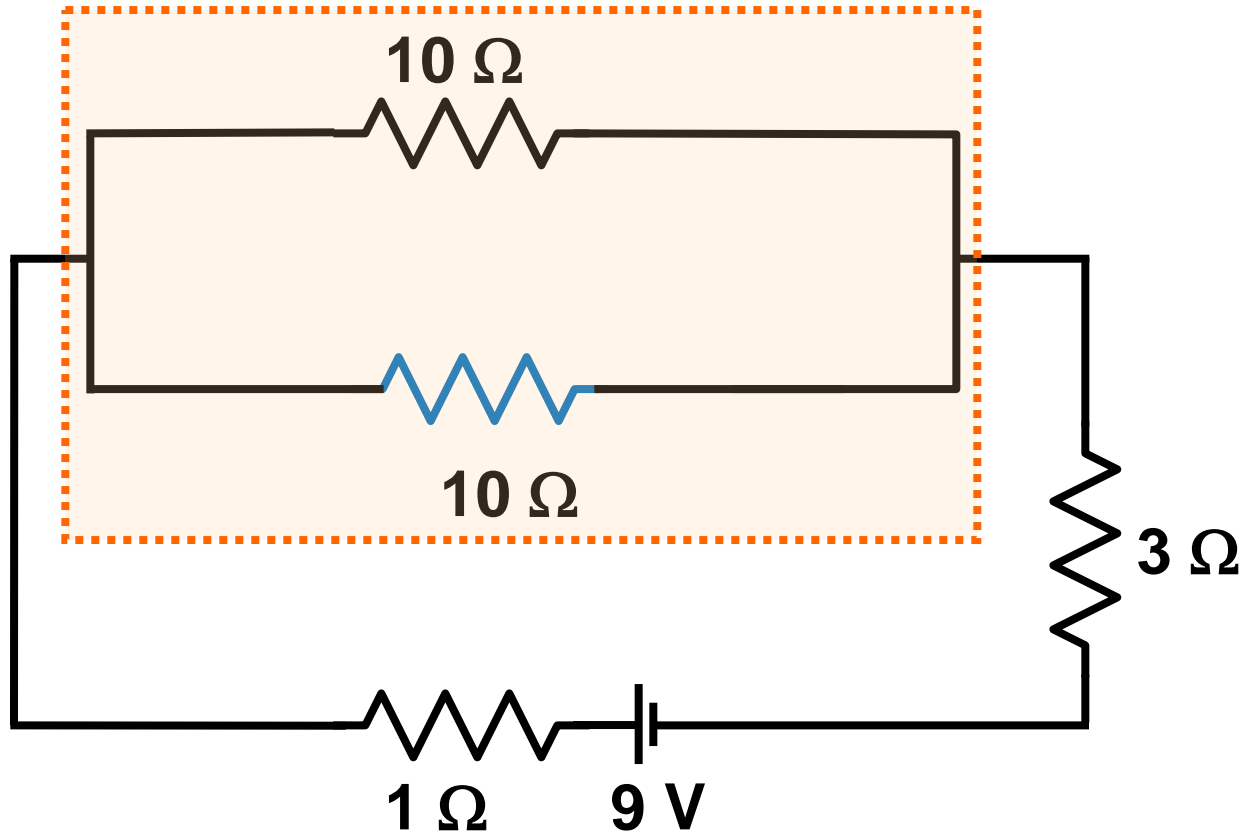

Replace the parallel combination (orange) by its equivalent.

We are left with an equivalent circuit of 3 resistors in series, which is easy handle.

Now perform the actual calculation a step at a time.

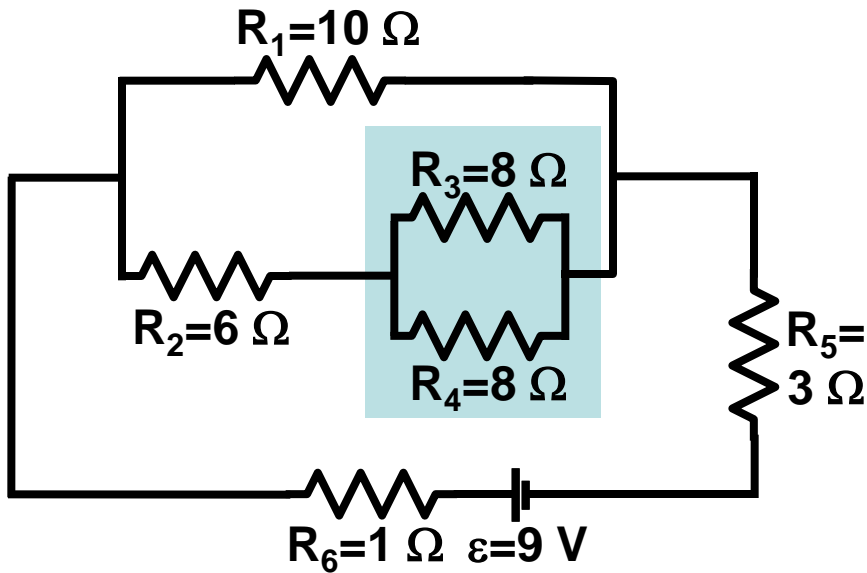

R_3 and R_4 are in parallel.

$$\frac{1}{R_{34}} = \frac{1}{R_3} + \frac{1}{R_4} = \frac{1}{8} + \frac{1}{8} = \frac{2}{8} = \frac{1}{4}$$

$$R_{34} = 4 \Omega$$

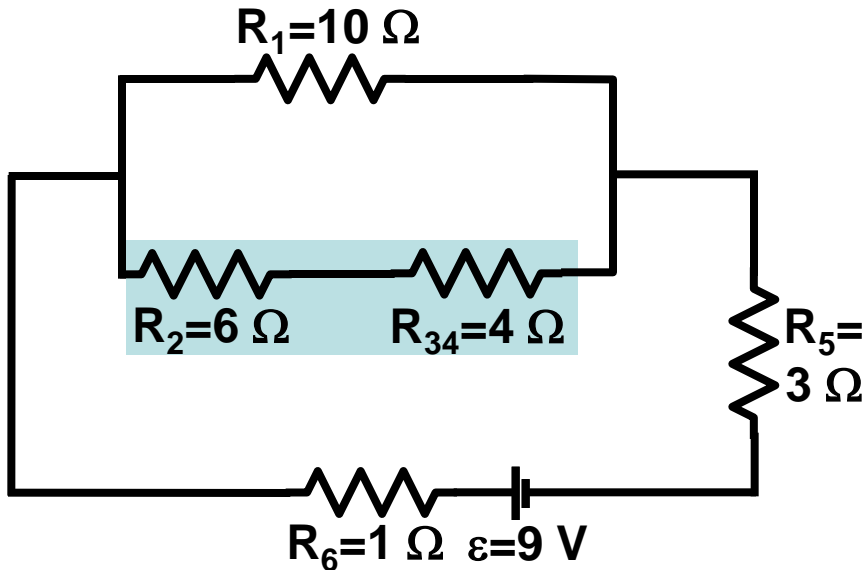

R_2 and R_{34} are in series.

$$R_{234} = R_2 + R_{34} = 6 + 4 = 10 \Omega$$

Let's shrink the diagram a bit, and work this a step at a time.

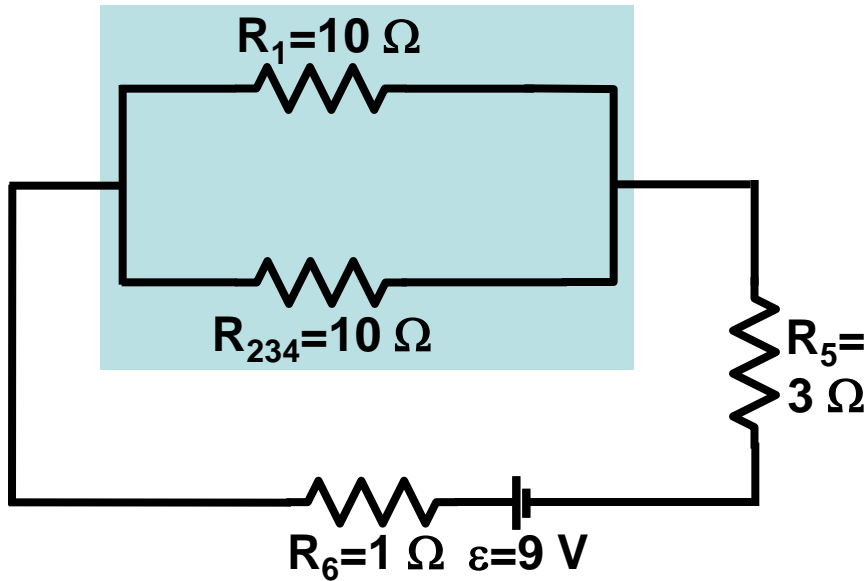

R_1 and R_{234} are in parallel.

$$\frac{1}{R_{1234}} = \frac{1}{R_1} + \frac{1}{R_{234}} = \frac{1}{10} + \frac{1}{10} = \frac{2}{10} = \frac{1}{5}$$

$$R_{1234} = 5\ \Omega$$

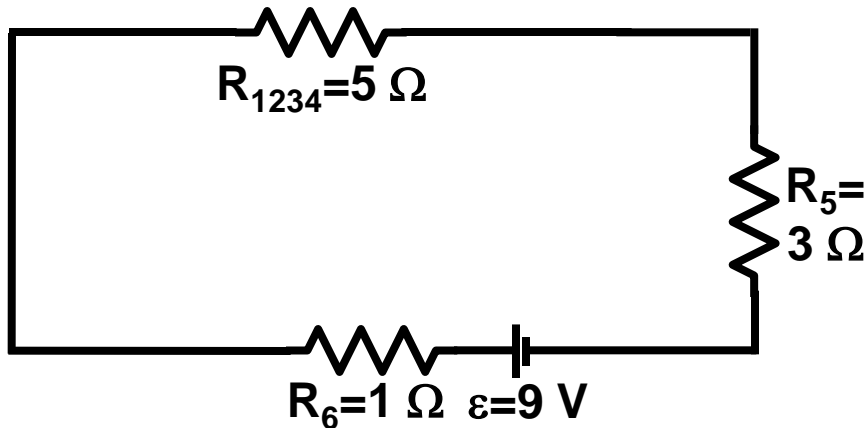

R_{1234} , R_5 and R_6 are in series.

$$R_{\text{eq}} = R_{1234} + R_5 + R_6 = 5 + 3 + 1$$

$$R_{\text{eq}} = 9\ \Omega$$

Calculate the current drawn from the battery.

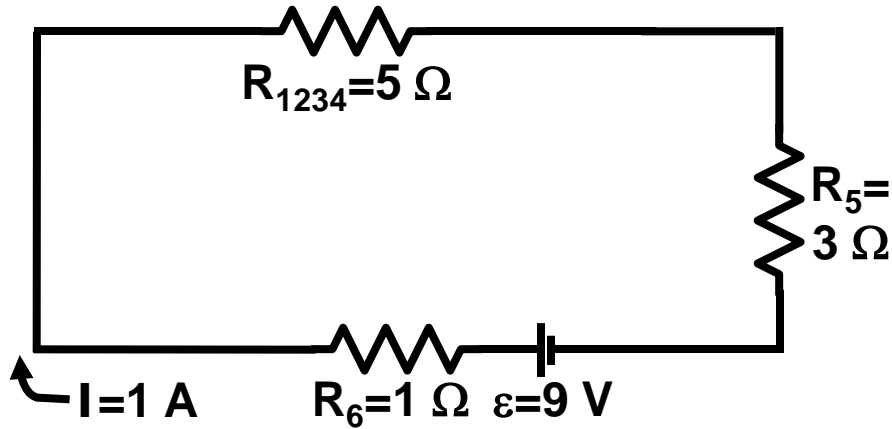

$$R_{\text{eq}} = 9 \Omega$$

$$V = IR$$

$$I = \frac{\varepsilon}{R_{\text{eq}}} = \frac{9}{9} = 1 \text{ A}$$

Find the current in the 6 Ω resistor.

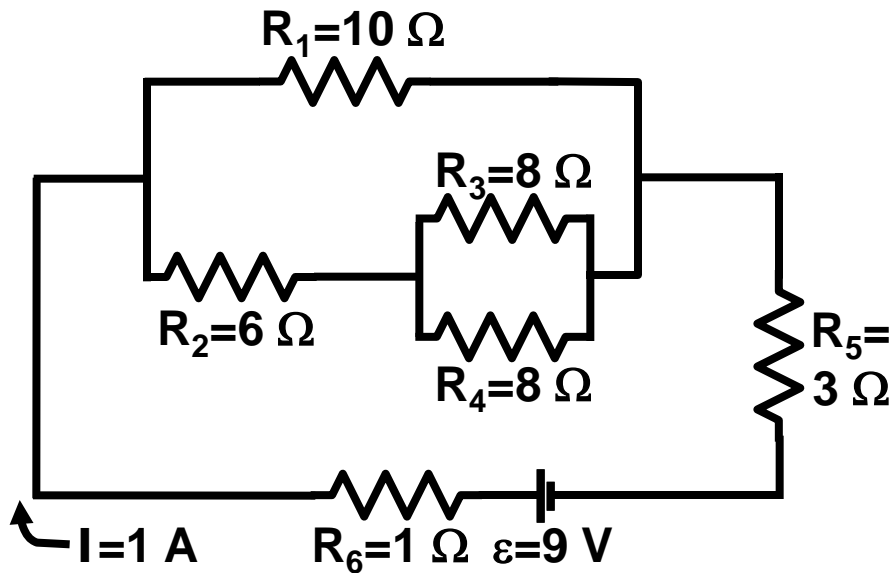

There are many ways to do the calculation. This is just one.

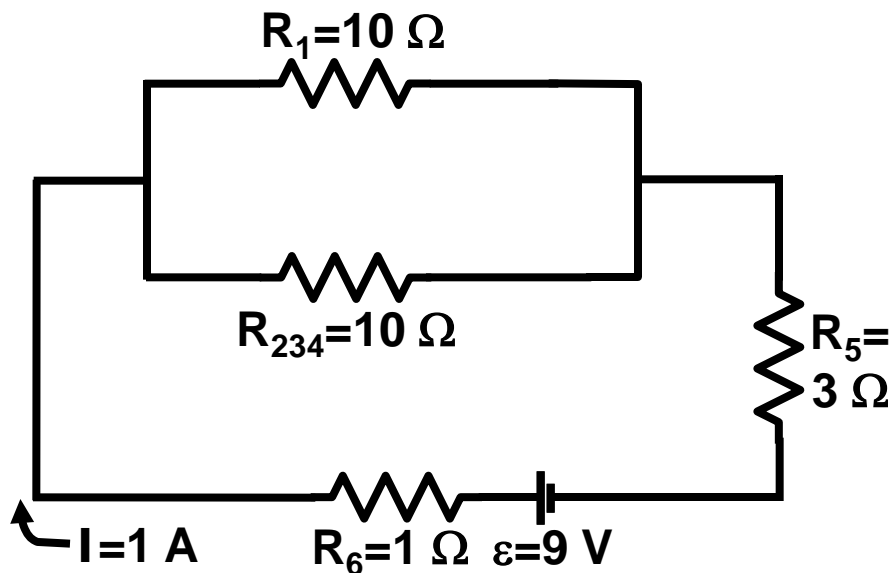

$$V_1 = V_{234} = V_{1234} \text{ (parallel).}$$

Find the current in the 6 Ω resistor.

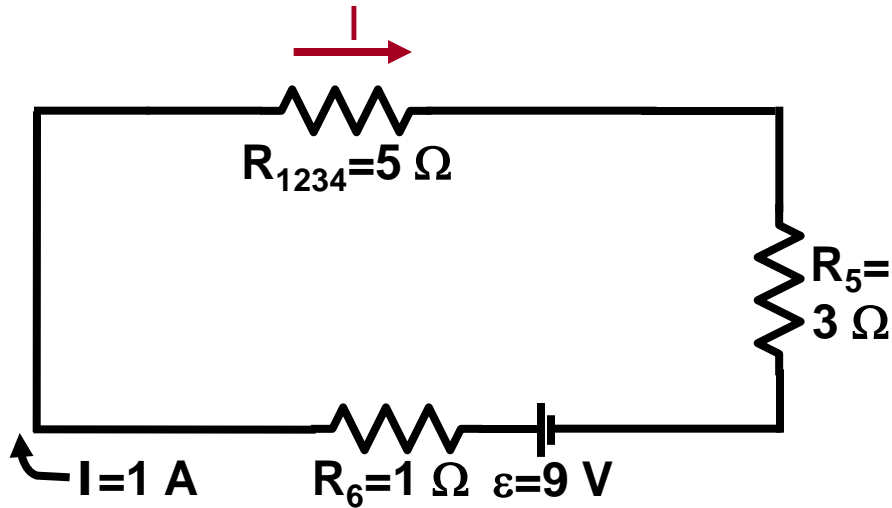

$$V_{1234} = I R_{1234} = (1)(5) = 5\text{ V}$$

$$V_1 = V_{234} = 5\text{ V}$$

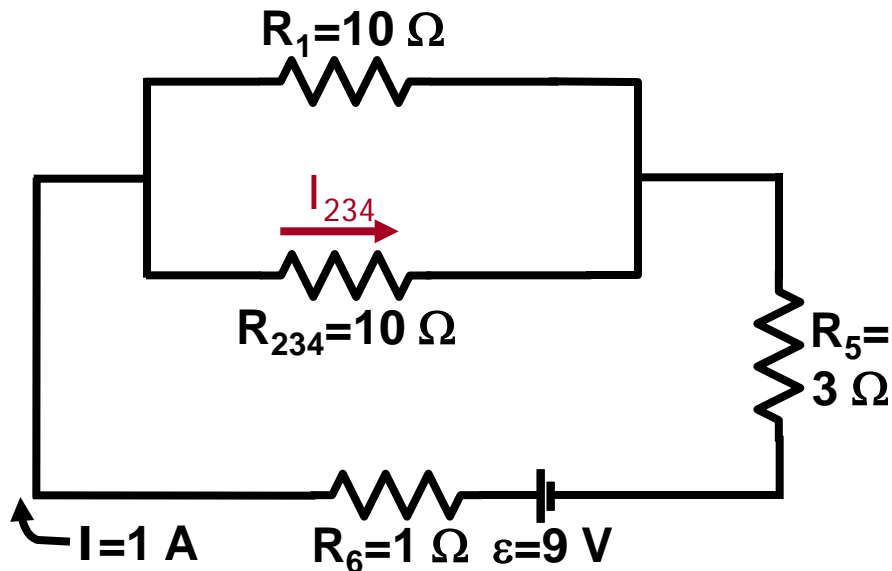

$$V_{234} = I_{234} R_{234}$$

$$I_{234} = V_{234} / R_{234} = 5/10$$

$$I_{234} = 0.5\text{ A}$$

Find the current in the $6\ \Omega$ resistor.

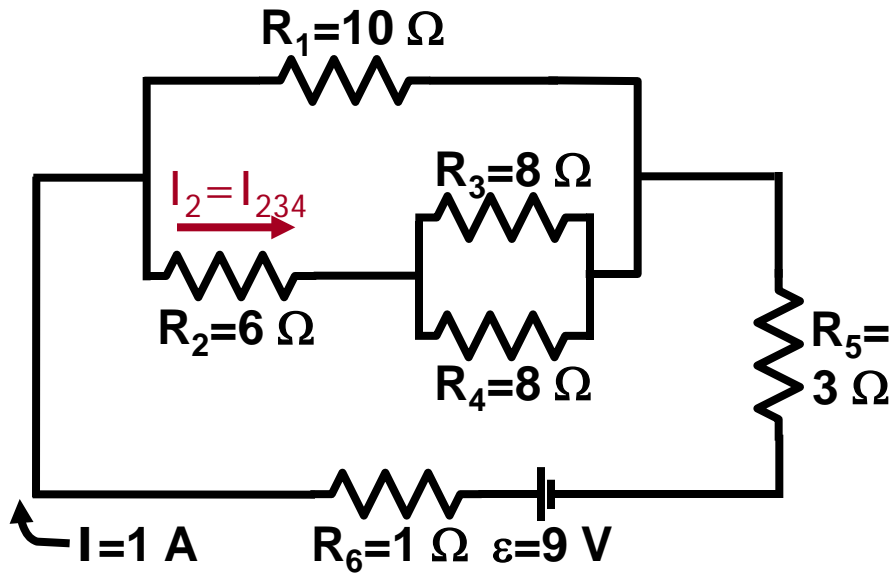

$$I_{234} = I_2 = I_{34} = 0.5\text{ A}$$

$$I_2 = 0.5\text{ A}$$

Find the current in the $6\ \Omega$ resistor.

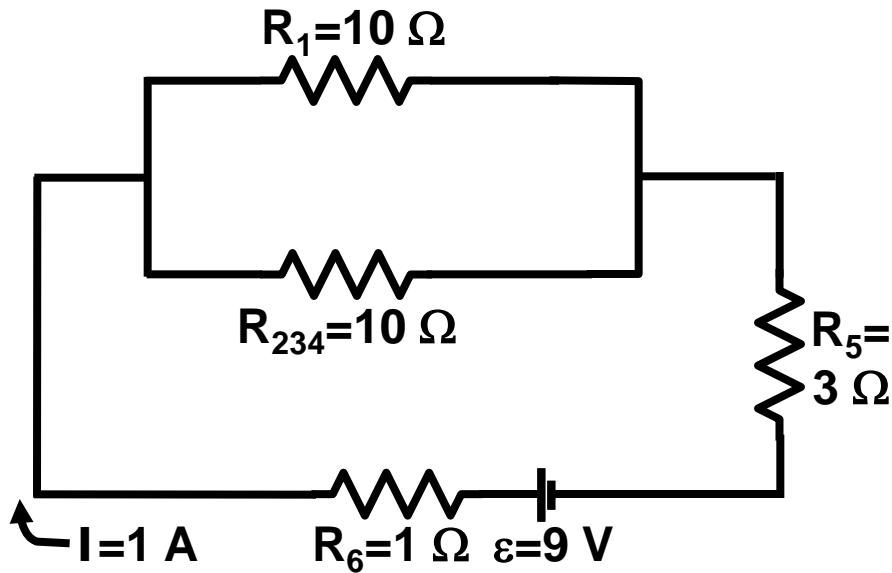

A student who has taken a circuits class will probably say

$$R_1 = R_{234}$$

$$\text{so } I_1 = I_{234} = I/2 = 0.5\text{ A}$$

If you want to do this on the exam, make sure you write down your justification on the exam paper, and don't make a mistake! If you don't show work and make a mistake, we can't give partial credit.

Answers without work shown generally receive no credit.

Example: two $100\ \Omega$ light bulbs are connected (a) in series and (b) in parallel to a $24\ \text{V}$ battery. For which circuit will the bulbs be brighter?

1. parallel (left)
2. series (right)

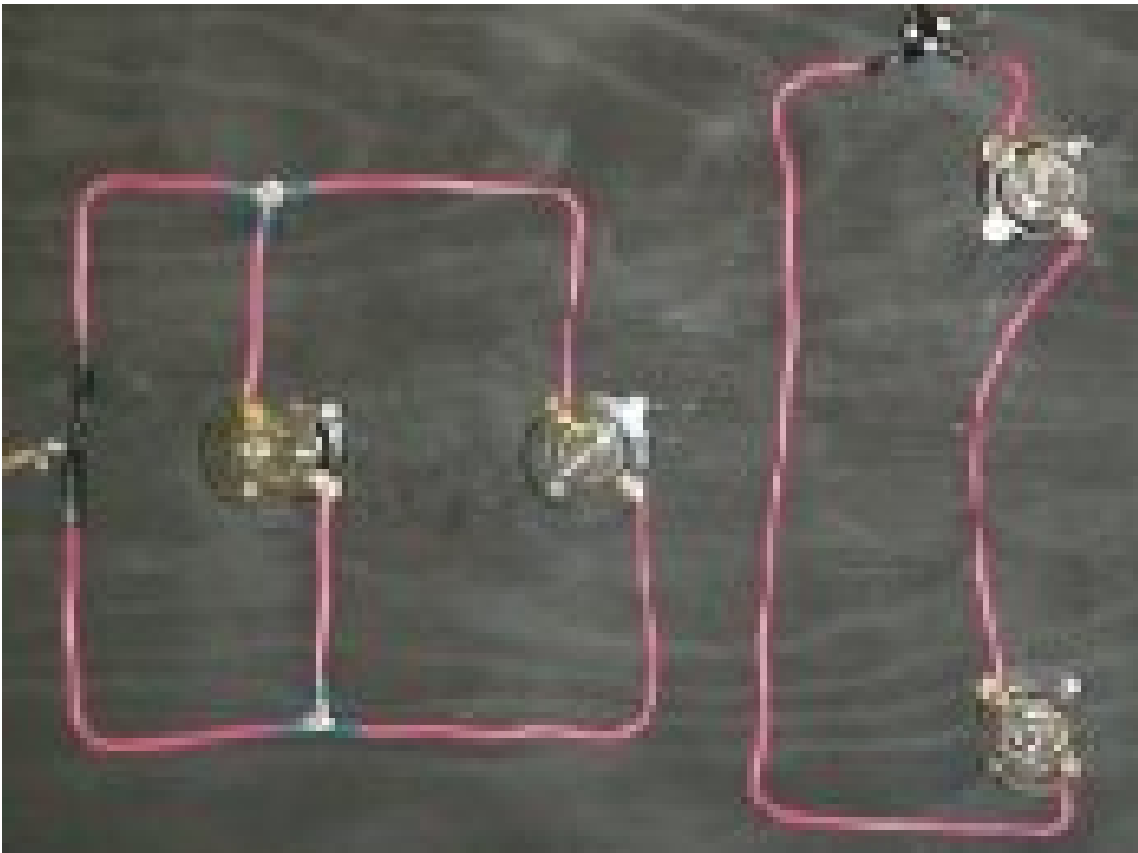

Example: two $100\ \Omega$ light bulbs are connected (a) in series and (b) in parallel to a $24\ \text{V}$ battery. **What is the current through each bulb?** For which circuit will the bulbs be brighter?

(a) Series combination.

$$R_{\text{eq}} = R_1 + R_2$$

$$V = I R_{\text{eq}}$$

$$V = I (R_1 + R_2)$$

$$I = V / (R_1 + R_2) = 24\ \text{V} / (100\ \Omega + 100\ \Omega) = \boxed{0.12\ \text{A}}$$

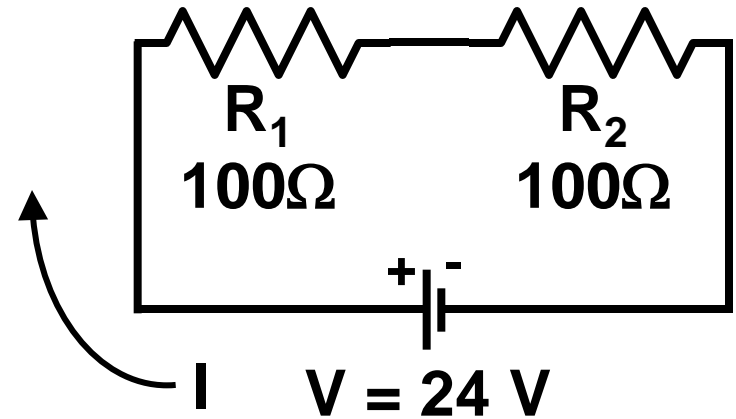

Example: two $100\ \Omega$ light bulbs are connected (a) in series and (b) in parallel to a $24\ \text{V}$ battery. **What is the current through each bulb?** For which circuit will the bulbs be brighter?

(b) Parallel combination.

$$\frac{1}{R_{\text{eq}}} = \frac{1}{R_1} + \frac{1}{R_2} = \frac{1}{100} + \frac{1}{100} = \frac{2}{100}$$

$$R_{\text{eq}} = 50\ \Omega$$

$$V = I R_{\text{eq}} \Rightarrow I = \frac{V}{R_{\text{eq}}}$$

$$I = \frac{24}{50} = 0.48\ \text{A}$$

$$I_1 = I_2 = \frac{I}{2} = 0.24\ \text{A} \quad (\text{because } R_1 = R_2)$$

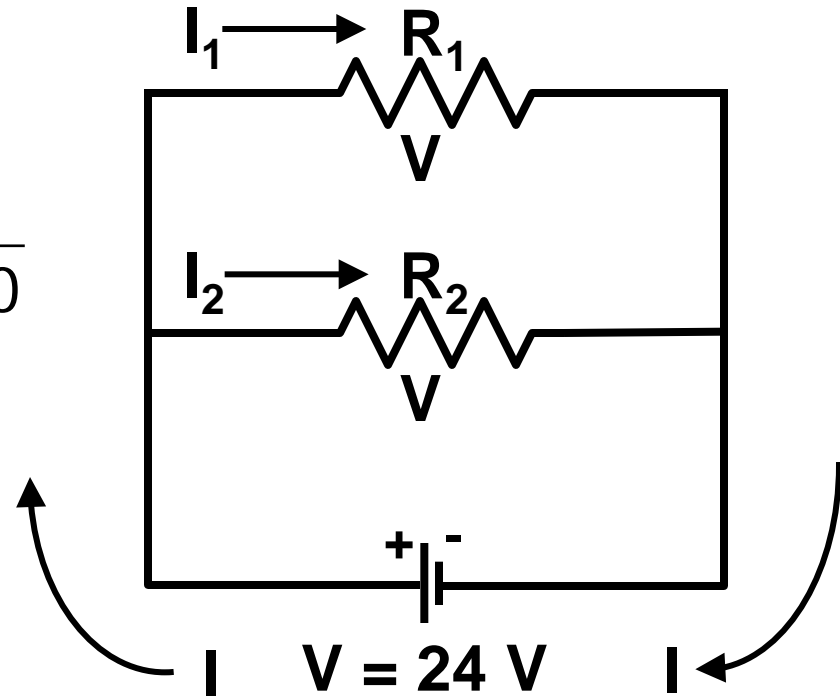

Example: two $100\ \Omega$ light bulbs are connected (a) in series and (b) in parallel to a $24\ \text{V}$ battery. What is the current through each bulb? **For which circuit will the bulbs be brighter?**

Calculate the power dissipated in the bulbs. The more power “consumed,” the brighter the bulb.

In other words, we use power as a proxy for brightness.

Example: two $100\ \Omega$ light bulbs are connected (a) in series and (b) in parallel to a $24\ \text{V}$ battery. What is the current through each bulb? **For which circuit will the bulbs be brighter?**

(a) Series combination.

for each bulb:

$$P = I^2 R$$

$$P = (0.12\ \text{A})^2 (100\ \Omega)$$

$$P = 1.44\ \text{W}$$

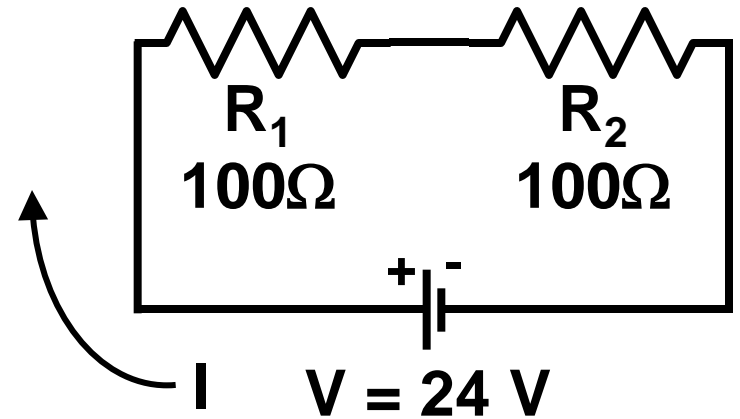

Example: two $100\ \Omega$ light bulbs are connected (a) in series and (b) in parallel to a $24\ \text{V}$ battery. What is the current through each bulb? **For which circuit will the bulbs be brighter?**

(b) Parallel combination.

for each bulb:

$$P = V^2 / R$$

$$P = (24\ \text{V})^2 / (100\ \Omega)$$

$$P = 5.76\ \text{W}$$

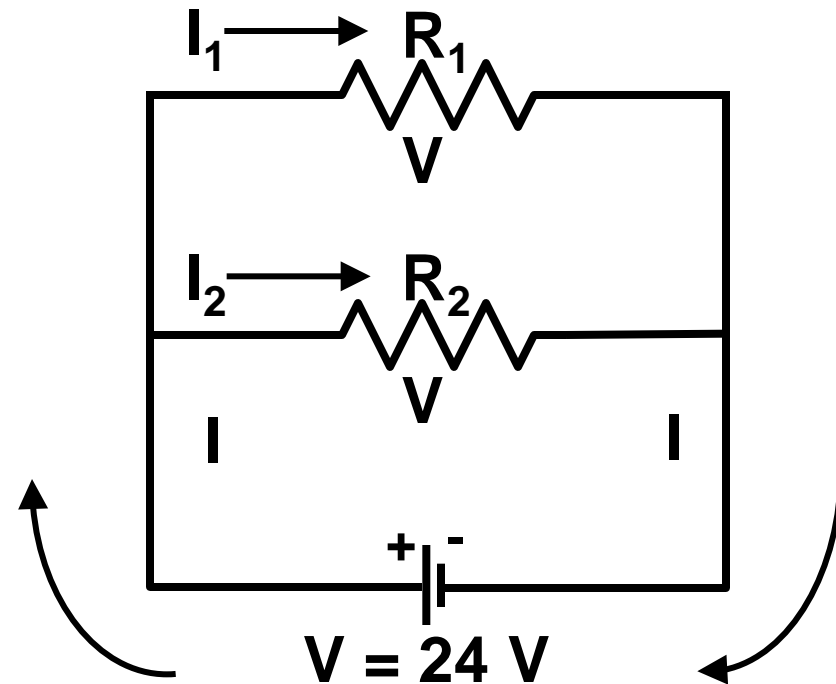

We also know each current, so we could have used $P = I^2R$.

Example: two $100\ \Omega$ light bulbs are connected (a) in series and (b) in parallel to a $24\ \text{V}$ battery. What is the current through each bulb? **For which circuit will the bulbs be brighter?**

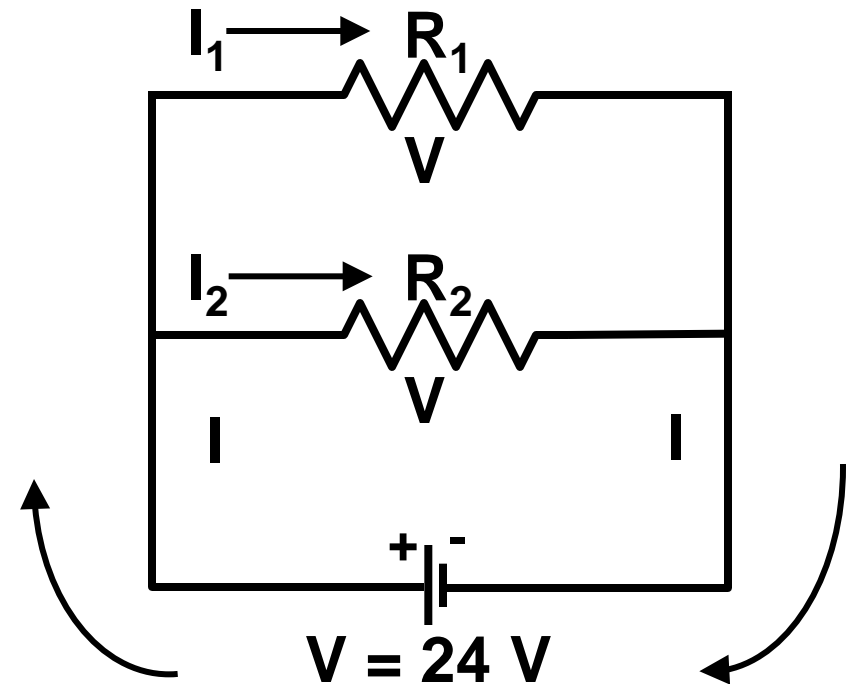
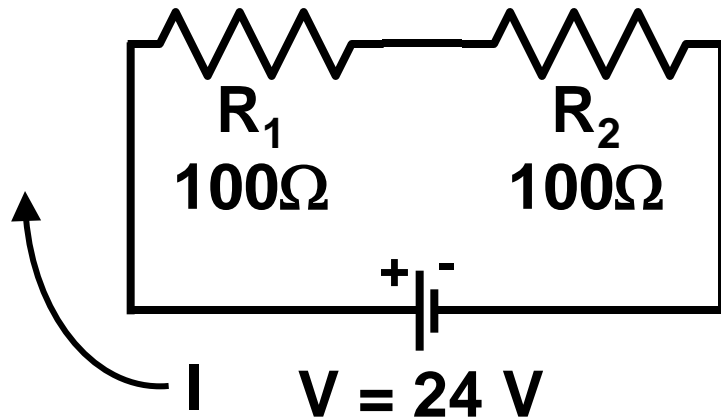

Compare: $P_{\text{series}} = 1.44\ \text{W}$

$$P_{\text{parallel}} = 5.76\ \text{W}$$

The bulbs in parallel are brighter.

This is what you see if you connect 40 W bulbs directly to a 120 V outlet. (DO NOT TRY AT HOME.)

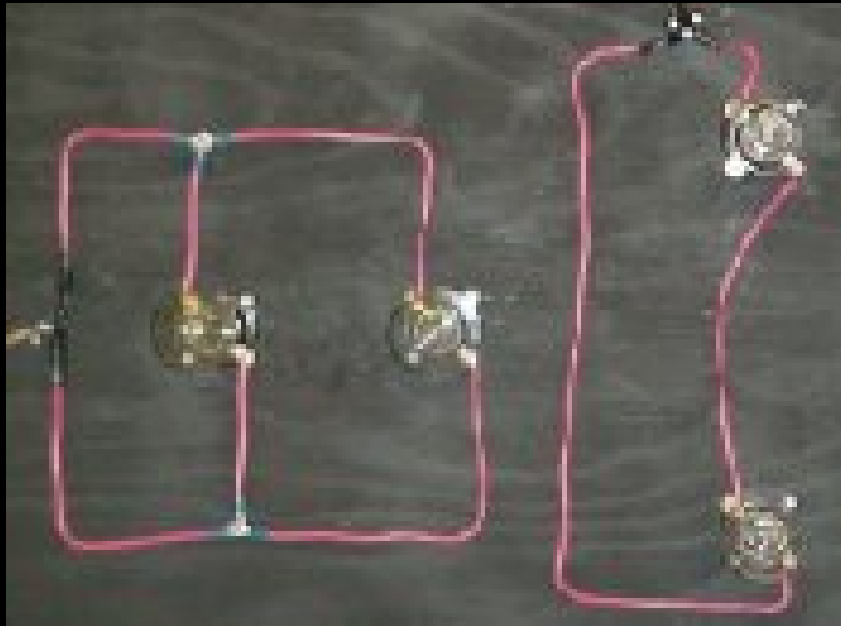

Off

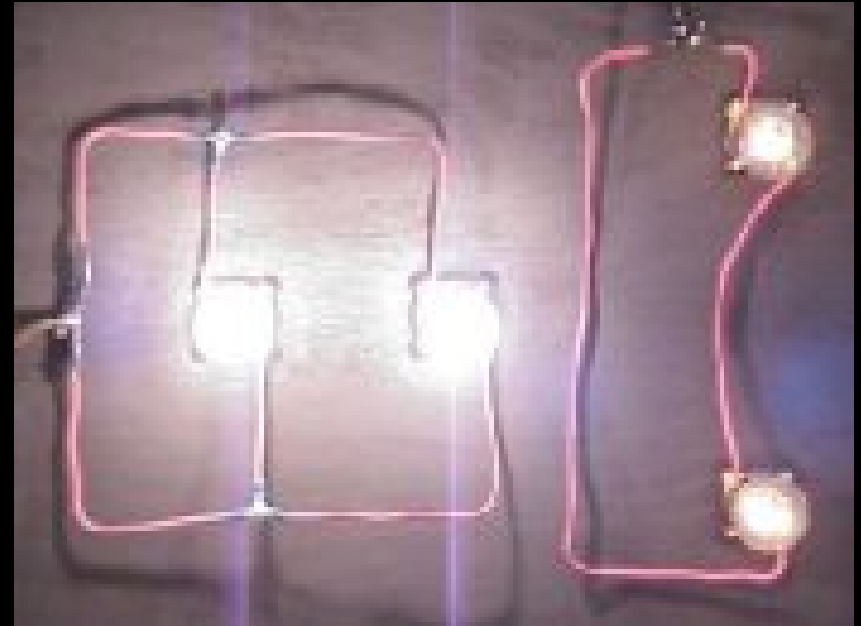

On

Today's agenda:

Resistors in Series and Parallel.

You must be able to calculate currents and voltages in circuit components in series and in parallel.

Kirchoff's Rules.

You must be able to use Kirchoff's Rules to calculate currents and voltages in circuit components that are not simply in series or in parallel.

A nontrivial circuit

Analyze this circuit for me, please. Find the currents I_1 , I_2 , and I_3 .

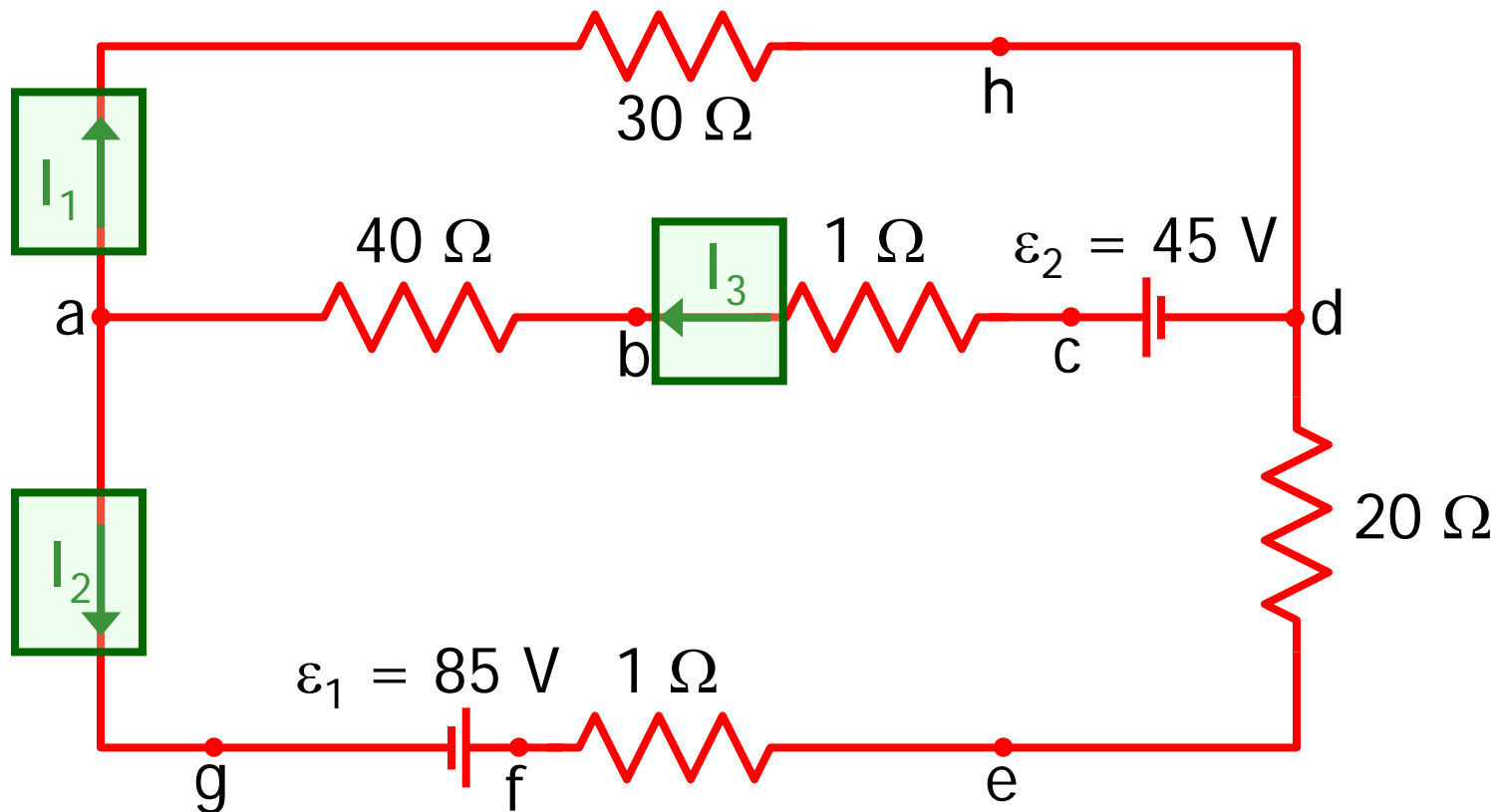

Two sets of resistors in series.

This.

And this.

Further analysis is difficult. `series1` seems to be in parallel with the $30\ \Omega$ resistor, but what about ε_2 ?

We need **new tools** to analyze that combination.

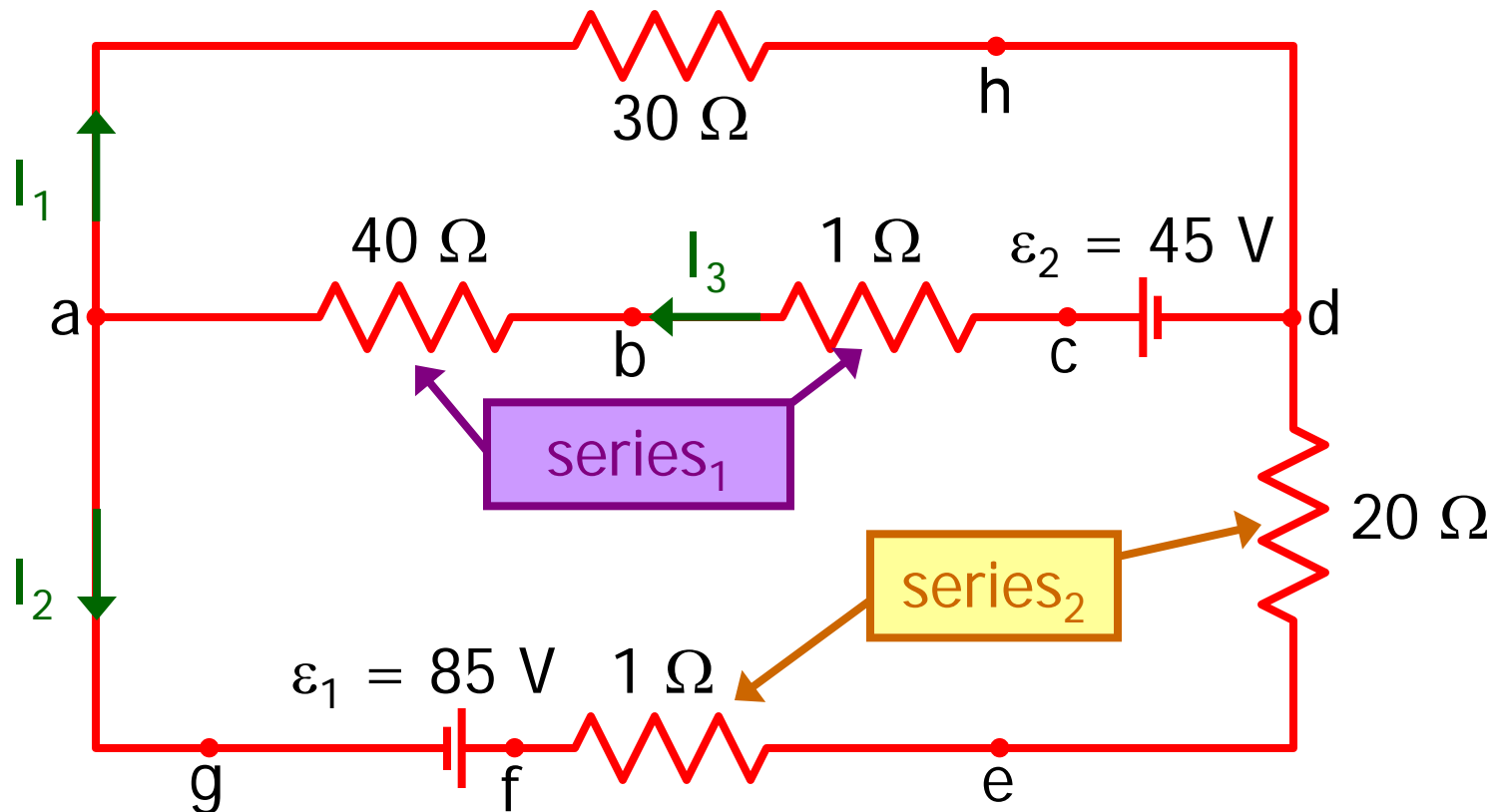

Kirchhoff's Rules

Kirchhoff's Loop Rule: (see last lecture)

The sum of potential changes around any closed path in a circuit is zero.

$$\sum V = 0 \quad \text{around any closed loop}$$

Energy conservation: a charge ending up where it started neither gains nor loses energy ($U_i = U_f$)

Kirchhoff's Junction Rule:

The sum of all currents entering a junction must equal the sum of all currents leaving the junction

$$\sum I = 0 \quad \text{at any junction}$$

Charge conservation: charge in = charge out

(current in counts +, current out counts -)

Recipe for problems that require Kirchhoff's rules

1. Draw the circuit.
2. Label the current in each branch of the circuit with a symbol (I_1, I_2, I_3, \dots) and an arrow (direction).
3. Apply Kirchhoff's Junction Rule at each junction. Current in is +, current out is -.
4. Apply Kirchhoff's Loop Rule for as many independent loops as necessary (pick travel direction and follow sign rules).

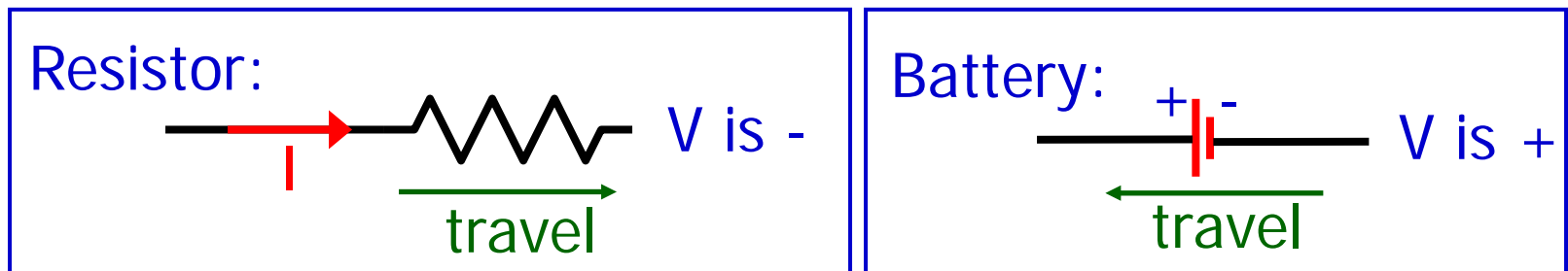

5. Solve resulting system of linear equations.

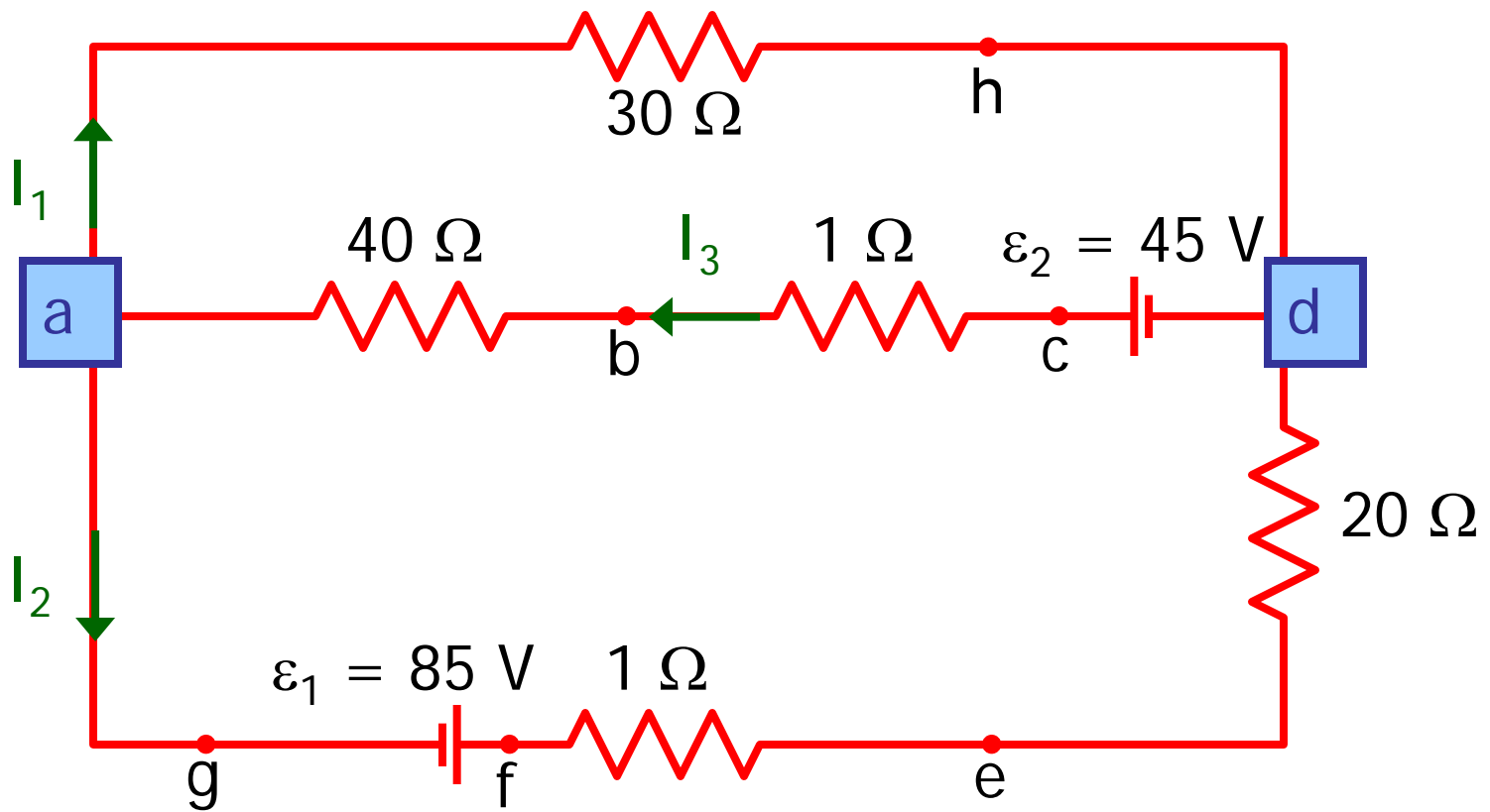

Back to our circuit: 3 unknowns (I_1 , I_2 , and I_3), so we will need 3 equations. We begin with the junctions.

Junction a: $I_3 - I_1 - I_2 = 0$ --eq. 1

Junction d: $-I_3 + I_1 + I_2 = 0$

Junction d gave no new information, so we still need two more equations.

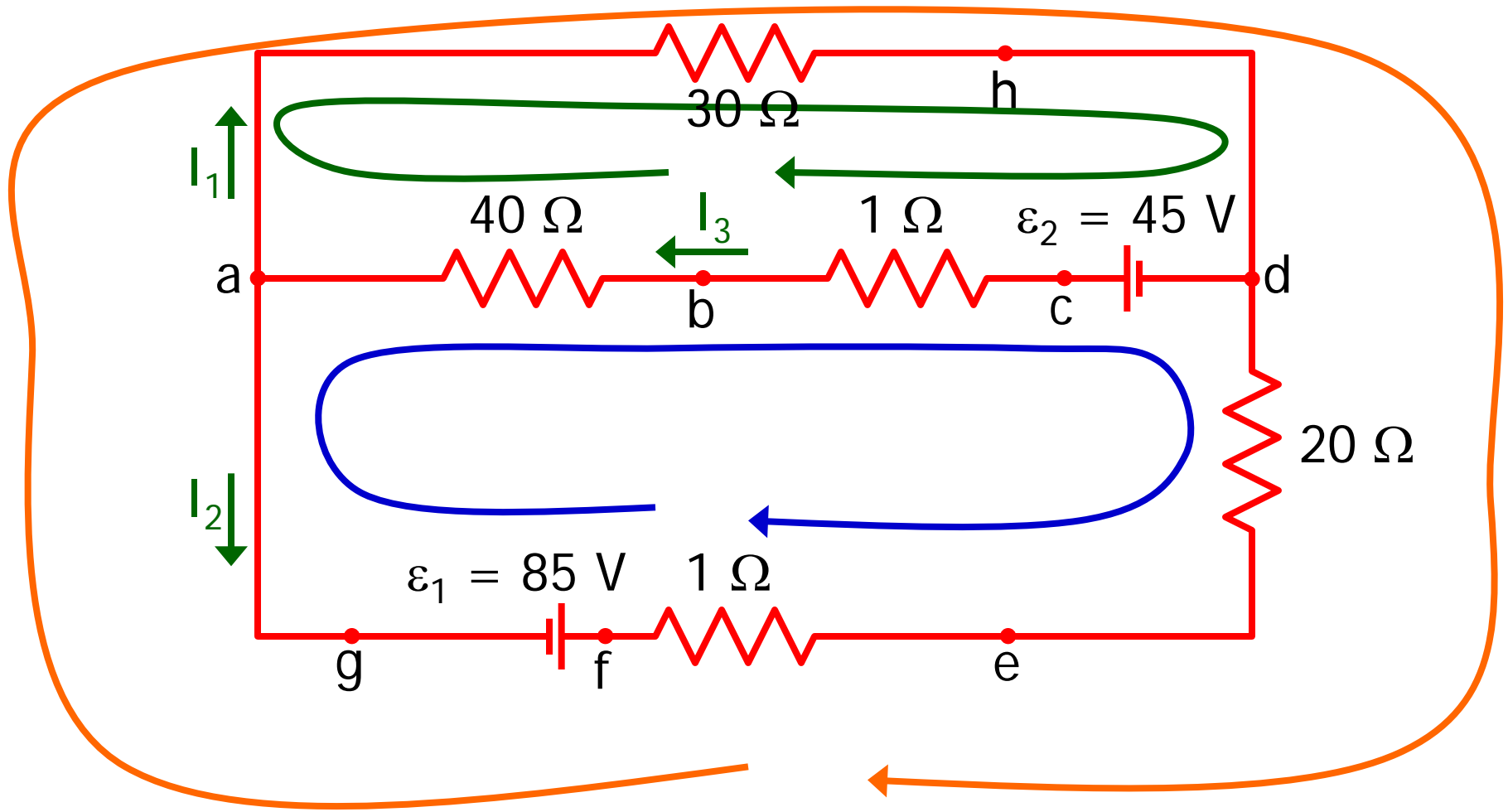

There are three loops.



Any two loops will produce independent equations. Using the third loop will provide no new information.

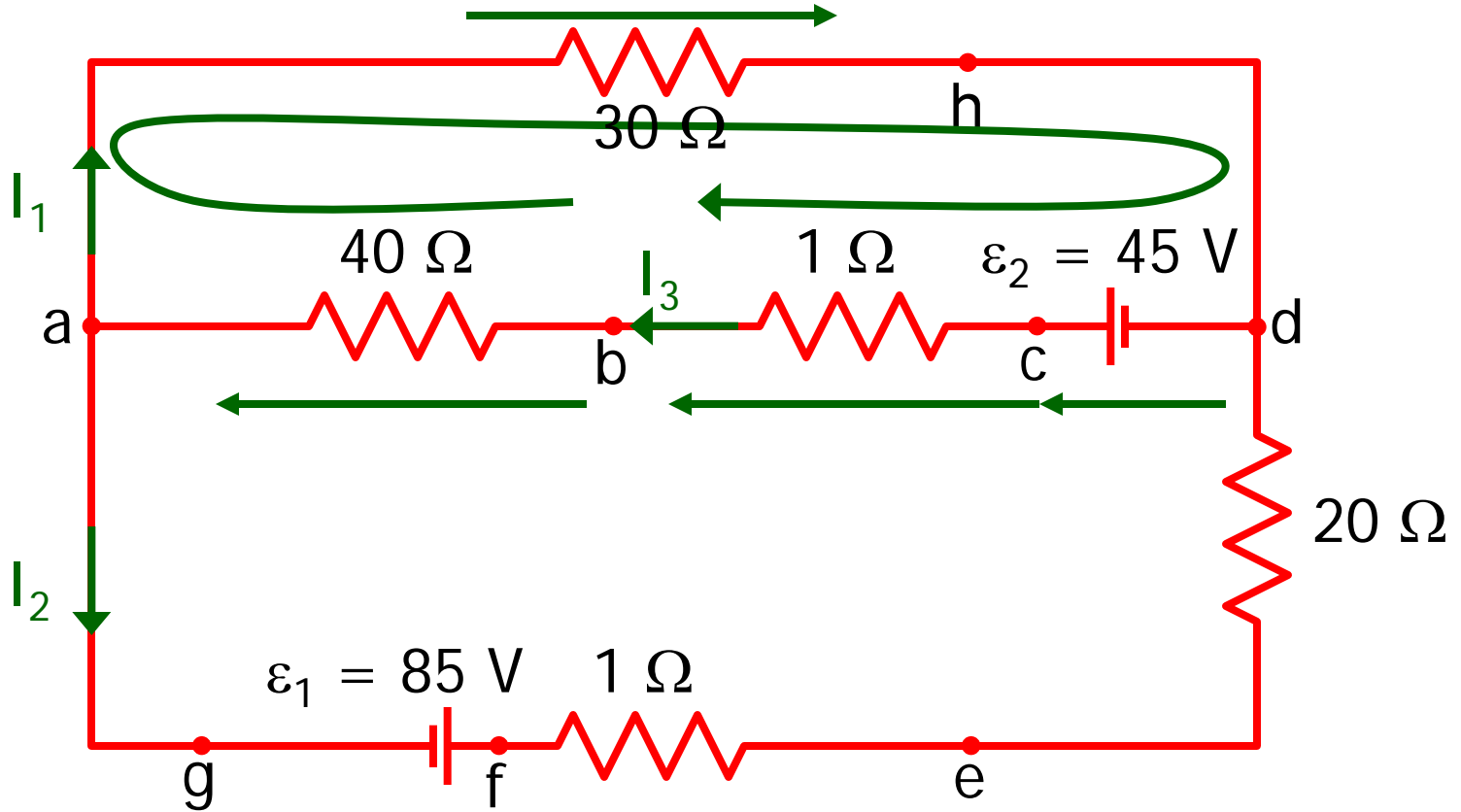

The "green" loop (a-h-d-c-b-a):

$$(- 30 I_1) + (+45) + (-1 I_3) + (- 40 I_3) = 0$$

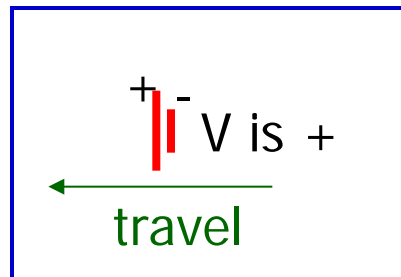
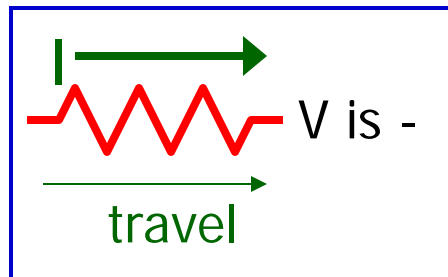

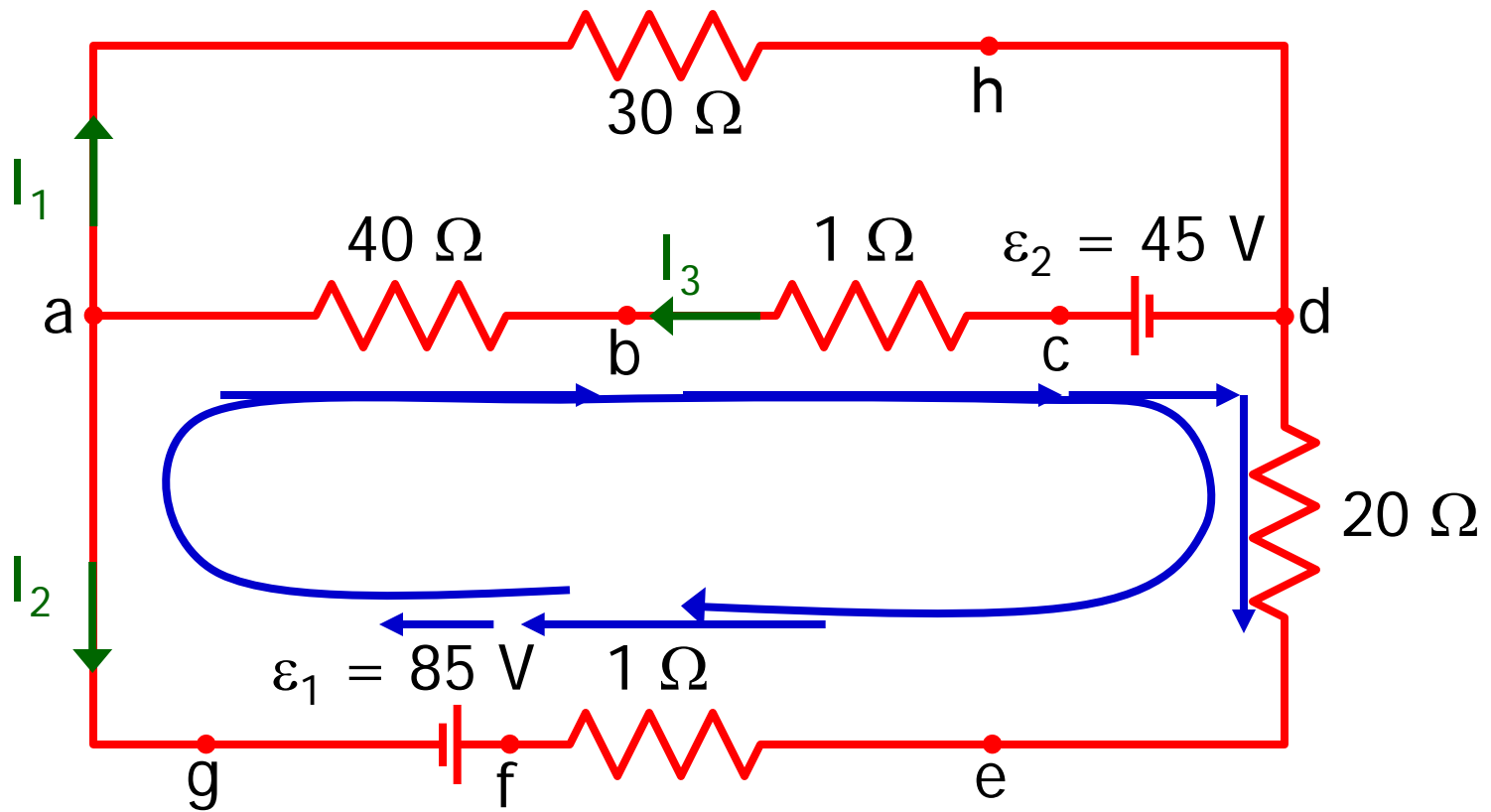

The "blue" loop (a-b-c-d-e-f-g):

$$(+ 40 I_3) + (+ 1 I_3) + (-45) + (+20 I_2) + (+1 I_2) + (-85) = 0$$

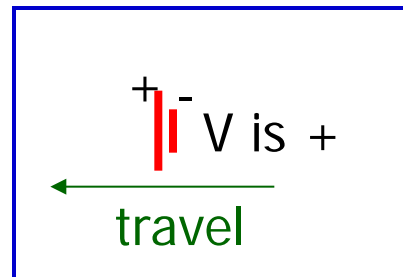
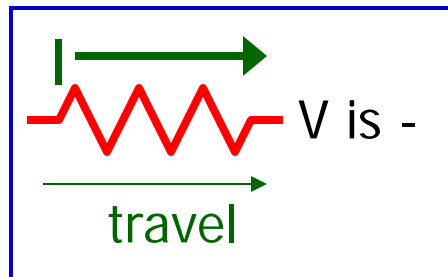

After combining terms and simplifying, we now have three equations, three unknowns; the rest is “just algebra.”

Junction a: $I_3 - I_1 - I_2 = 0$ --eq. 1

The “green” loop $- 30 I_1 + 45 - 41 I_3 = 0$ --eq. 2

The “blue” loop $41 I_3 - 130 + 21 I_2 = 0$ --eq. 3

skip the algebra!

Make sure to use voltages in V and resistances in Ω . Then currents will be in A.

You can see the solution in part 7 of today’s lecture notes

Collect our three equations:

$$I_3 - I_1 - I_2 = 0$$

$$- 30 I_1 + 45 - 41 I_3 = 0$$

$$41 I_3 - 130 + 21 I_2 = 0$$

Rearrange to get variables in "right" order:

$$- I_1 - I_2 + I_3 = 0$$

$$- 30 I_1 - 41 I_3 + 45 = 0$$

$$21 I_2 + 41 I_3 - 130 = 0$$

Use the middle equation to eliminate I_1 :

$$I_1 = (41 I_3 - 45)/(-30)$$

There are many valid sets of steps to solving a system of equations. Any that works is acceptable.

Two equations left to solve:

$$- (41 I_3 - 45)/(-30) - I_2 + I_3 = 0$$

$$21 I_2 + 41 I_3 - 130 = 0$$

Might as well work out the numbers:

$$1.37 I_3 - 1.5 - I_2 + I_3 = 0$$

$$21 I_2 + 41 I_3 - 130 = 0$$

$$- I_2 + 2.37 I_3 - 1.5 = 0$$

$$21 I_2 + 41 I_3 - 130 = 0$$

Multiply the top equation by 21:

$$- 21 I_2 + 49.8 I_3 - 31.5 = 0$$

$$21 I_2 + 41 I_3 - 130 = 0$$

Add the two equations to eliminate I_2 :

$$\begin{array}{r} - 21 I_2 + 49.8 I_3 - 31.5 = 0 \\ + (21 I_2 + 41 I_3 - 130 = 0) \\ \hline 90.8 I_3 - 161.5 = 0 \end{array}$$

Solve for I_3 :

$$\begin{aligned} I_3 &= 161.5 / 90.8 \\ I_3 &= 1.78 \end{aligned}$$

Go back to the "middle equation" two slides ago for I_1 :

$$\begin{aligned} I_1 &= (41 I_3 - 45)/(-30) \\ I_1 &= - 1.37 I_3 + 1.5 \\ I_1 &= - (1.37) (1.78) + 1.5 \\ I_1 &= - 0.94 \end{aligned}$$

Go back two slides to get an equation that gives I_2 :

$$-I_2 + 2.37 I_3 - 1.5 = 0$$

$$I_2 = 2.37 I_3 - 1.5$$

$$I_2 = (2.37) (1.78) - 1.5$$

$$I_2 = 2.72$$

Summarize answers (don't forget to show units):

$I_1 = -0.94 \text{ A}$
$I_2 = 2.72 \text{ A}$
$I_3 = 1.78 \text{ A}$

Are these currents correct? How could you tell? We'd better check our results.

$$I_3 - I_1 - I_2 = 0$$

$$-30 I_1 + 45 - 41 I_3 = 0$$

$$41 I_3 - 130 + 21 I_2 = 0$$

$$I_1 = -0.94 \text{ A}$$
$$I_2 = 2.72 \text{ A}$$
$$I_3 = 1.78 \text{ A}$$

Check: $1.78 - (-0.94) - 2.72 = 0$

$-30(-0.94) + 45 - 41(1.78) = 0.22$

$41(1.78) - 130 + 21(2.72) = 0.10$

Are the last two indications of a mistake or just roundoff error? Recalculating while retaining 2 more digits gives $I_1=0.933$, $I_2=2.714$, $I_3=1.7806$, and the last two results are 0.01 or less \Rightarrow roundoff was the culprit.

A Toy to Play With

<http://phet.colorado.edu/en/simulation/circuit-construction-kit-dc>

Circuit Construction Kit (DC Only)

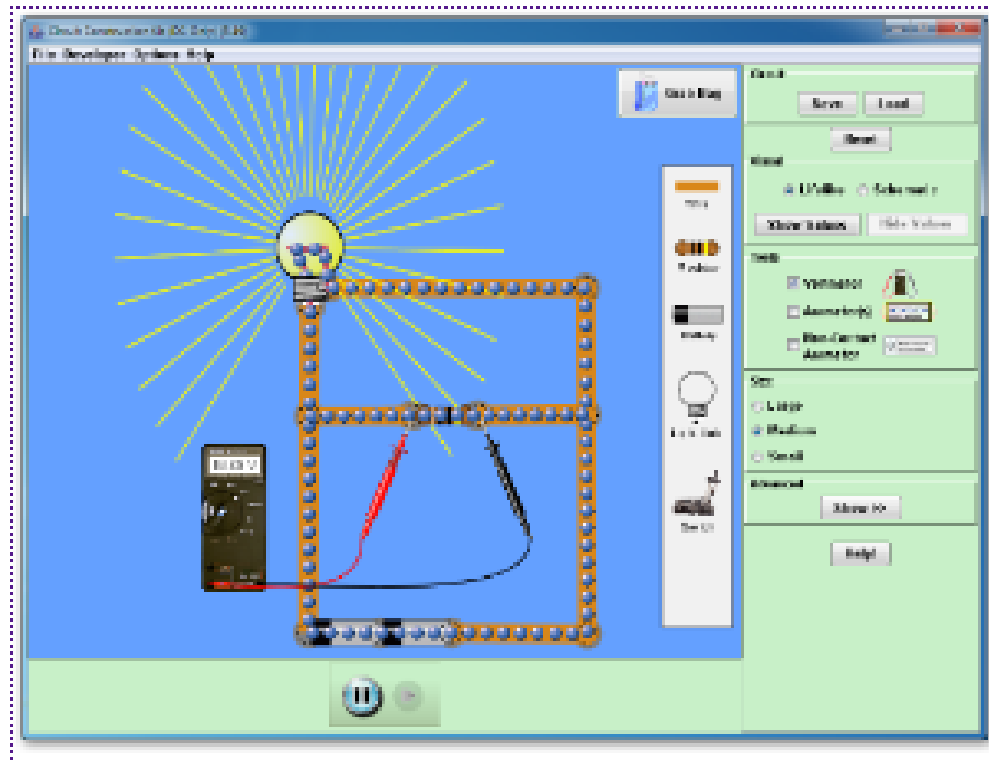

Download 2,103 kB

Run Now!

Embed

Version: 3.20 (change log)