

Exam I
Tuesday, February 19
5:00 – 6:00 pm

Topics from lectures 1-7

See Canvas or course web site for exam locations
by recitation section.

Exam I Review

Lecture consists of example problems.

- Problems are not an exhaustive set of the type that could be on the exam.
- Any material from lectures 1-7 and the associated recitations and readings may be on the exam.
- Work the problems first and then view the solutions.

Example: The force on q_1 due to the other charges is F_0 .
If all of the charges are tripled what will be the force on q_1 ?

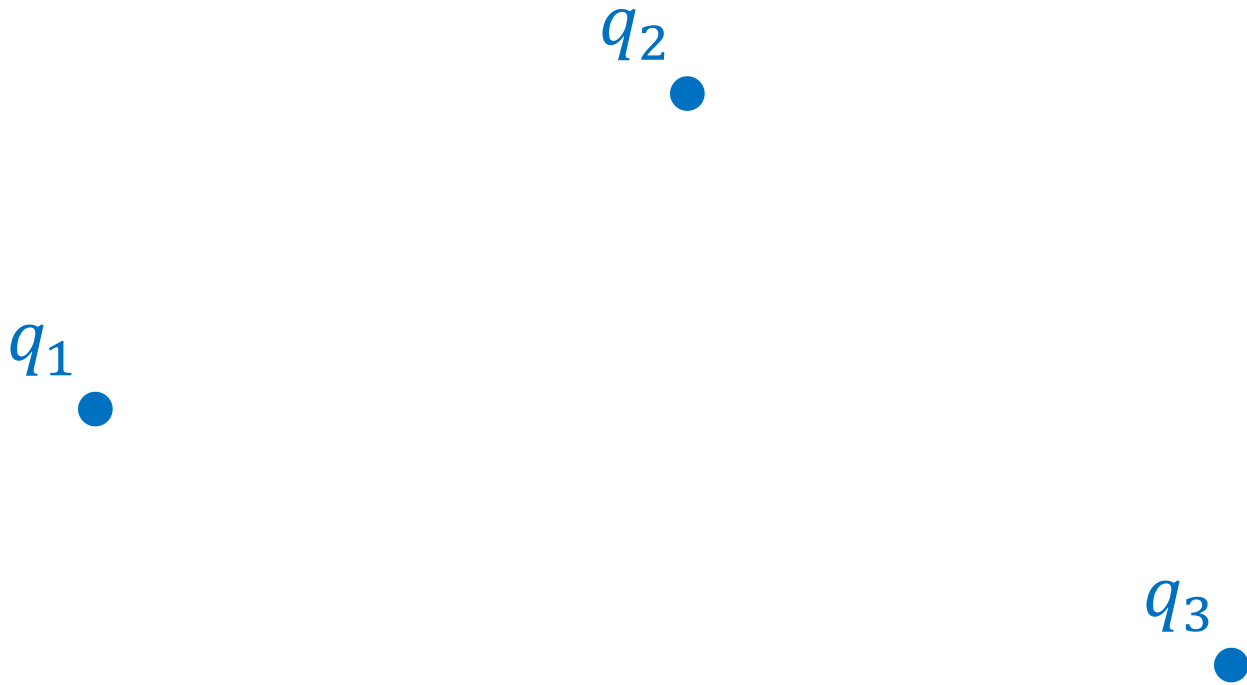

Example: The electric field at P is E_0 . At what distance from Q is the electric field $\frac{1}{100}E_0$?

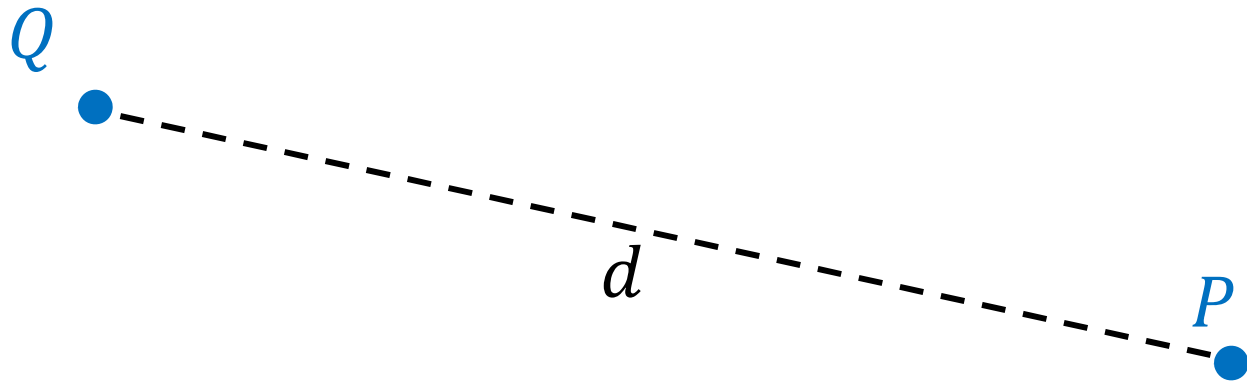

Example: (a) At which point (A or B) is the electric potential greater? (b) At which point is the magnitude of the electric field greater? (c) At which point would an electron have greater potential energy? (d) What direction would a proton accelerate in the field?

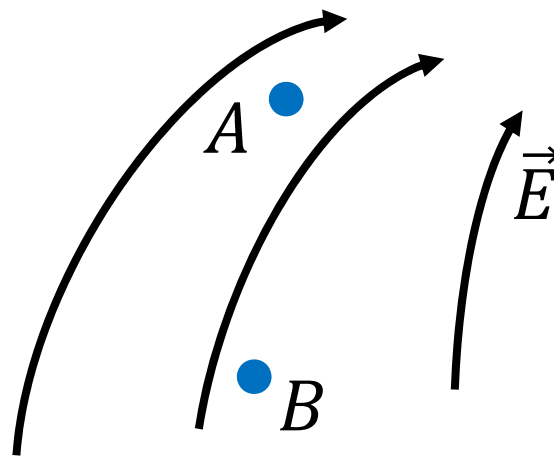

Example: Determine the electric field at the origin due to an arc of radius a and total charge Q .

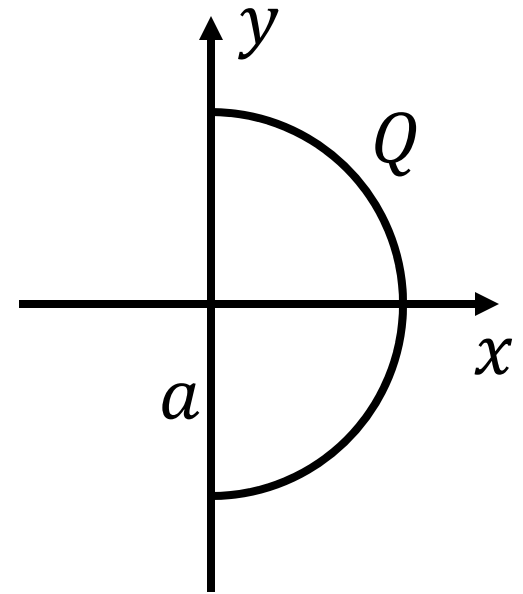

Example: Determine the electric potential at P due to the given arrangement of charges.

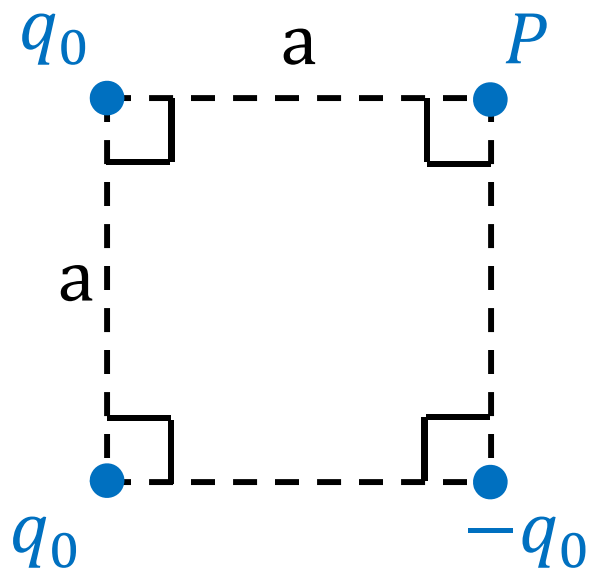

Example: Determine the charge on each capacitor and the potential difference across each capacitor.

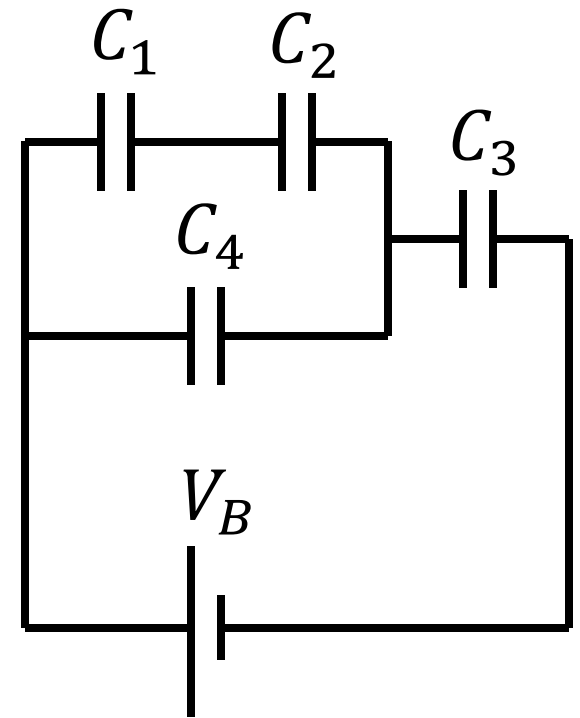

$$C_1 = 4\mu\text{F}$$

$$C_2 = 12\mu\text{F}$$

$$C_3 = 12\mu\text{F}$$

$$C_4 = 3\mu\text{F}$$

$$V_B = 9\text{V}$$

Example: A large insulating slab of width w has a uniform charge density ρ . Determine the electric field everywhere.

