

Exam Total

/200

Physics 2135 Final Exam
May 14, 2019

Printed Name: _____

Recitation: _____

1. Two point charges are located as shown in the figure: $-2Q$ is at (b, b) , and $+Q$ is at $(-a, 0)$.

(15) (a) Using the coordinate system given, calculate the total electric field at the origin due to **both** charges. Express your answer in unit vector notation.

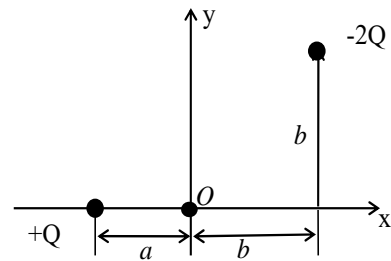

(5) (b) What is the electrical potential at the origin?

2. A solid insulating sphere of radius a has total charge Q uniformly distributed over its entire volume.

(20) Using Gauss's Law, find **the magnitude of the electric field** for $r < a$ in terms of a , r , Q , and k or ϵ_0 . Justify all steps leading to your answer. Draw an appropriate Gaussian surface on the diagram and label its radius.

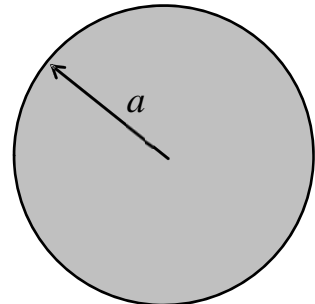

/40

3. Consider the illustrated circuit with the given resistances. The potential difference across resistor R_1 is $V_1 = 10\text{V}$.

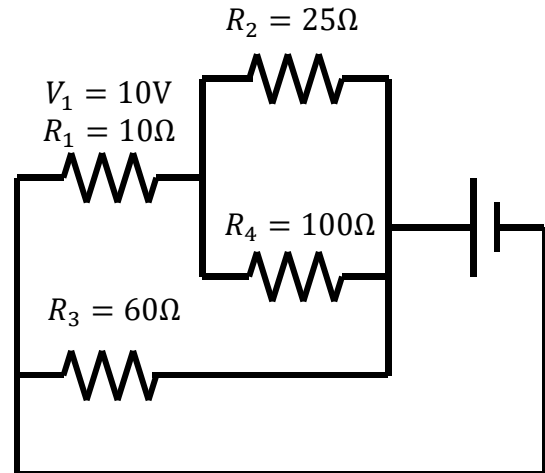

- (10) a. Determine R_T , the total equivalent resistance of the circuit.

- (10) b. Determine V_4 , the potential difference across R_4 .

- (10) c. Determine I_4 , the current through R_4 .

- (10) d. Determine P_4 , the power dissipated in R_4 .



4. Two long straight wires carry currents $I_1 = I_2 = I$ out of the page, as shown. One wire is located on the y -axis. The second wire is located on the x -axis. Both are located a distance a from the origin.

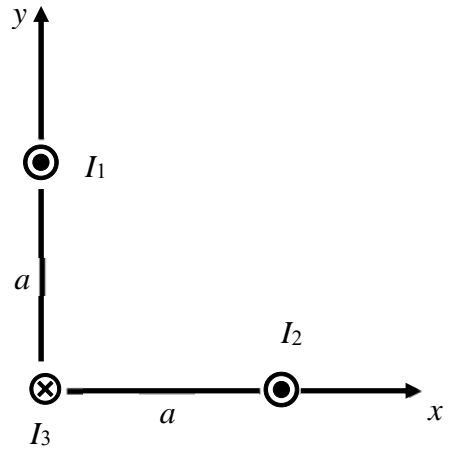

- (20) Calculate the net force that these two wires exert on a third wire of length L carrying a current $I_3 = 2I$ into the page at the origin. Express your answer in unit vector notation.

5. A wire loop of resistance R is bent into the shape of a right triangle with short sides of length a and b . The side of length b is attached to an axle that allows it to be spun about the x -axis, as shown. A uniform magnetic field of strength B , directed along the positive z -axis, is maintained throughout the entire region.

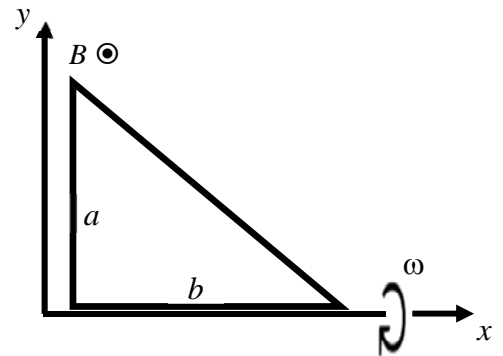

- (8) (a) At the moment when the top of the triangle is rotating out of the page what direction is the induced **current** in the triangular loop? (Circle one.)

- (12) (b) Find the maximum net current induced in the triangular loop as it is spun about the x -axis with angular frequency ω , as shown.

6. A candle is placed in front of a convex mirror with radius of 20cm. The image is 0.25 times the size of the object.

(5) (a) Is the image REAL or VIRTUAL (circle one)?

(5) (b) Is the image UPRIGHT or INVERTED (circle one)?

(10) (c) Calculate the object distance.

(10) (d) Calculate the image distance.

(10) (e) The candle is now placed 15cm in front of the mirror. Construct a ray diagram using two principal rays to locate the image. Adjacent tic marks on the optic axis (called principal axis in lectures) are separated by 5.0cm.

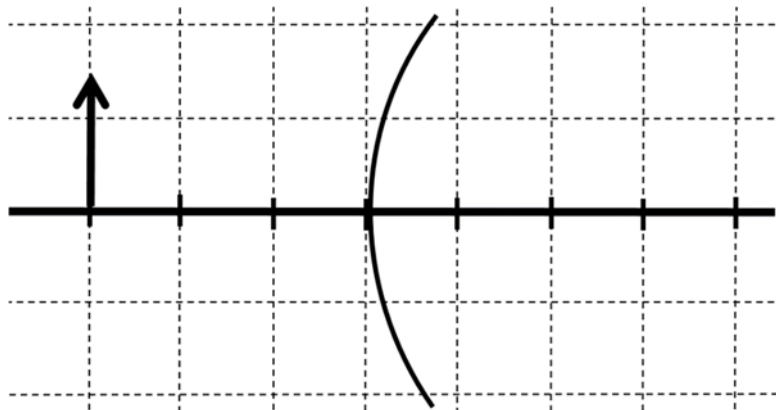

7. Last month the Event Horizon Telescope (EHT) released the first-ever image of a black hole from a distant galaxy. EHT achieved an incredibly small angular resolution of $\Delta\theta$ ($\sim 10^{-10}$ radian!) by “interference”. For simplicity consider interference with two radio telescopes as shown by the upper figure.

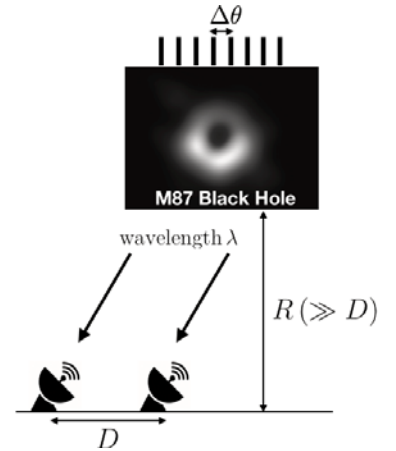

- (5) (a) Find the frequency f of the radio wave when its wavelength is $\lambda = 1\text{mm}$. To get full credit, give **both symbolic and numerical answers**.

- (15) (b) This situation is an analog of the two-slit interference problem as indicated by the next figure. Using the small-angle approximation, find the spacing Δy of neighboring fringes. **Give a symbolic expression in terms of D , R , λ , and constants**.

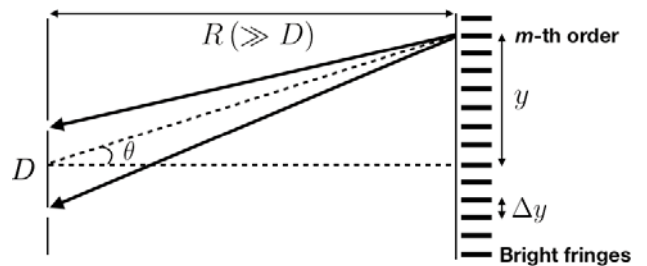

- (10) (c) Based on the analog, find the distance between two telescopes D . **Give a symbolic expression in terms of $\Delta\theta$, λ and constants**. [Hint: The angular resolution $\Delta\theta$ corresponds to the ‘angular’ fringe spacing.]

8. Laser light of wavelength λ_0 is traveling in air and shining on a layer of material “A” whose refractive index is n_A . When the layer is coated on another material “B” with a refractive index n_B , constructive interference is observed.

- (10) When $1 < n_B < n_A$, find the minimum thickness of the material “A” layer.