

**Official Starting Equations**  
**PHYS 2135, Engineering Physics II**

**From PHYS 1135:**

$$x = x_0 + v_{0x}\Delta t + \frac{1}{2}a_x(\Delta t)^2 \quad v_x = v_{0x} + a_x\Delta t \quad v_x^2 = v_{0x}^2 + 2a_x(x - x_0) \quad \sum \vec{F} = m\vec{a}$$

$$F_r = -\frac{mv_t^2}{r} \quad P = \frac{F}{A} \quad \vec{p} = m\vec{v} \quad P = \frac{dW}{dt} \quad W = \int \vec{F} \cdot d\vec{s}$$

$$K = \frac{1}{2}mv^2 \quad U_f - U_i = -W_{\text{conservative}} \quad E = K + U \quad E_f - E_i = (W_{\text{other}})_{i \rightarrow f} \quad E = P_{\text{ave}}t$$

**Constants:**

$$g = 9.8 \frac{\text{m}}{\text{s}^2} \quad m_{\text{electron}} = 9.11 \times 10^{-31} \text{kg} \quad m_{\text{proton}} = 1.67 \times 10^{-27} \text{kg} \quad e = 1.6 \times 10^{-19} \text{C}$$

$$c = 3.0 \times 10^8 \frac{\text{m}}{\text{s}} \quad k = \frac{1}{4\pi\epsilon_0} = 9 \times 10^9 \frac{\text{Nm}^2}{\text{C}^2} \quad \epsilon_0 = 8.85 \times 10^{-12} \frac{\text{C}^2}{\text{Nm}^2} \quad \mu_0 = 4\pi \times 10^{-7} \frac{\text{Tm}}{\text{A}}$$

**Electric Force, Field, Potential and Potential Energy:**

$$\vec{F} = k \frac{q_1 q_2}{r_{12}^2} \hat{r}_{12} \quad \vec{E} = k \frac{q}{r^2} \hat{r} \quad \vec{F} = q\vec{E} \quad \Delta V = -\int_i^f \vec{E} \cdot d\vec{s}$$

$$U = k \frac{q_1 q_2}{r_{12}} \quad V = k \frac{q}{r} \quad \Delta U = q\Delta V \quad E_x = -\frac{\partial V}{\partial x}$$

$$\vec{p} = q\vec{d} \text{ (from - to +)} \quad \vec{\tau} = \vec{p} \times \vec{E} \quad U_{\text{dipole}} = -\vec{p} \cdot \vec{E}$$

$$\Phi_E = \int_S \vec{E} \cdot d\vec{A} \quad \oint_S \vec{E} \cdot d\vec{A} = \frac{q_{\text{enclosed}}}{\epsilon_0} \quad \lambda \equiv \frac{\text{charge}}{\text{length}} \quad \sigma \equiv \frac{\text{charge}}{\text{area}} \quad \rho \equiv \frac{\text{charge}}{\text{volume}}$$

**Circuits:**

$$C = \frac{Q}{V} \quad \frac{1}{C_T} = \sum \frac{1}{C_i} \quad C_T = \sum C_i \quad C_0 = \frac{\epsilon_0 A}{d} \quad C = \kappa C_0$$

$$U = \frac{1}{2}CV^2 = \frac{1}{2}\frac{Q^2}{C} = \frac{1}{2}QV \quad I = \frac{dq}{dt} \quad J = \frac{I}{A} \quad \vec{J} = nq\vec{v}_d$$

$$\vec{J} = \sigma\vec{E} \quad V = IR \quad R = \rho \frac{L}{A} \quad \sigma = \frac{1}{\rho} \quad \rho = \rho_0[1 + \alpha(T - T_0)]$$

$$\sum I = 0 \quad \sum \Delta V = 0 \quad \frac{1}{R_T} = \sum \frac{1}{R_i} \quad R_T = \sum R_i \quad P = IV = \frac{V^2}{R} = I^2 R$$

$$Q(t) = Q_{\text{final}}[1 - e^{-t/\tau}] \quad Q(t) = Q_0 e^{-t/\tau} \quad \tau = RC$$

**Integral:**

$$\int \frac{du}{(u^2 + a^2)^{3/2}} = \frac{u}{a^2 \sqrt{u^2 + a^2}} + c$$

### Magnetic Force, Field and Inductance:

$$\begin{aligned}\vec{F} &= q(\vec{E} + \vec{v} \times \vec{B}) & \vec{F} &= I\vec{L} \times \vec{B} & \Phi_B &= \int \vec{B} \cdot d\vec{A} & \oint \vec{B} \cdot d\vec{A} &= 0 \\ \oint \vec{B} \cdot d\vec{s} &= \mu_0 I_{\text{enclosed}} & \vec{\mu} &= NI\vec{A} & \vec{\tau} &= \vec{\mu} \times \vec{B} & U_{\text{dipole}} &= -\vec{\mu} \cdot \vec{B} \\ \vec{B} &= \frac{\mu_0 q \vec{v} \times \hat{r}}{4\pi r^2} & d\vec{B} &= \frac{\mu_0 I}{4\pi} \frac{d\vec{s} \times \hat{r}}{r^2} & \mathcal{E} &= -N \frac{d\Phi_B}{dt} & \oint \vec{E} \cdot d\vec{s} &= -\frac{d\Phi_B}{dt} \\ \oint \vec{B} \cdot d\vec{s} &= \mu_0 I_{\text{enclosed}} + \mu_0 \epsilon_0 \frac{d\phi_E}{dt} & B &= \frac{\mu_0 I}{2\pi} & B &= \mu_0 nI\end{aligned}$$

### Electromagnetic Waves:

$$\begin{aligned}I &= \frac{P}{A} & u &= \frac{1}{2}(\epsilon_0 E^2 + \frac{B^2}{\mu_0}) = \epsilon_0 E^2 = \frac{B^2}{\mu_0} & \langle u \rangle &= \frac{1}{4}(\epsilon_0 E_{\text{max}}^2 + \frac{B_{\text{max}}^2}{\mu_0}) = \frac{1}{2}\epsilon_0 E_{\text{max}}^2 = \frac{B_{\text{max}}^2}{2\mu_0} \\ \frac{E}{B} &= c = \frac{1}{\sqrt{\epsilon_0 \mu_0}} & \vec{S} &= \frac{1}{\mu_0} \vec{E} \times \vec{B} & I &= \langle S \rangle = c \langle u \rangle & \langle P_{\text{rad}} \rangle &= \frac{I}{c} \text{ or } \frac{2I}{c} \\ k &= \frac{2\pi}{\lambda} & \omega &= 2\pi f & T &= \frac{1}{f} & v &= f\lambda = \frac{\omega}{k} = \frac{c}{n}\end{aligned}$$

### Optics:

$$\begin{aligned}I &= I_{\text{max}} \cos^2 \phi & \theta_r &= \theta_i & n &= \frac{c}{v} = \frac{\lambda_0}{\lambda_n} & n_r \sin \theta_r &= n_i \sin \theta_i \\ \frac{1}{s} + \frac{1}{s'} &= \frac{1}{f} & m &= \frac{y'}{y} = -\frac{s'}{s} & \frac{1}{f} &= (n-1) \left( \frac{1}{R_1} - \frac{1}{R_2} \right) & f &= \frac{R}{2} \\ \frac{n_a}{s} + \frac{n_b}{s'} &= \frac{n_b - n_a}{R} & m &= \frac{y'}{y} = -\frac{n_a s'}{n_b s} & \Delta L &= m\lambda & \Delta L &= \left(m + \frac{1}{2}\right)\lambda \\ \Delta L &= d \sin \theta & \phi &= 2\pi \left(\frac{\Delta L}{\lambda}\right) & I &= I_0 \cos^2 \frac{\phi}{2} & R &= \frac{\lambda}{\Delta \lambda} = Nm \\ m\lambda &= a \sin \theta & \beta &= \frac{2\pi}{\lambda} a \sin \theta & I &= I_0 \left[ \frac{\sin(\beta/2)}{\beta/2} \right]^2\end{aligned}$$

### Integral:

$$\int \frac{du}{(u^2 + a^2)^{3/2}} = \frac{u}{a^2 \sqrt{u^2 + a^2}} + c$$

Exam Total
/200

**PHYS 2135 Exam II**  
**March 22, 2022**

Name: \_\_\_\_\_ Section: \_\_\_\_\_

For questions 1-5, select the best answer. For problems 6-9, solutions must begin with an Official Starting Equation, when appropriate. Work must be shown to receive credit. Calculators are not allowed. Use appropriate units. Provide answers in terms of given variables and fundamental constants.

(8) \_\_\_\_\_ **1.** A parallel plate capacitor with an air gap holds a charge  $Q_0$  when connected to a particular battery. While the capacitor is still connected to the battery, the gap is filled with a dielectric with  $\kappa > 1$  and now holds a charge  $Q_f$ . Select the correct statement.

- [A]  $Q_f < Q_0$
- [B]  $Q_f = Q_0$
- [C]  $Q_f > Q_0$
- [D] There is not enough information provided to select one of the other answers.

(8) \_\_\_\_\_ **2.** Which of the following is a valid application of Kirchoff's Loop Rule for the given circuit with the current directions indicated?

- [A]  $V_B - I_1 R_1 + I_2 R_2 = 0$
- [B]  $-I_1 R_1 + I_2 R_2 = 0$
- [C]  $-I_1 R_1 - I_2 R_2 = 0$
- [D]  $I_T = I_1 + I_2$

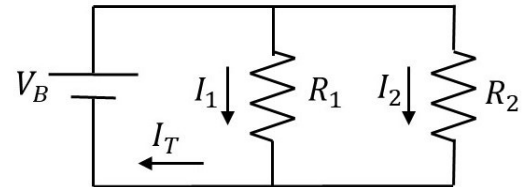

(8) \_\_\_\_\_ **3.** RC circuit 1 consists of a 8V battery, a  $24\mu\text{F}$  capacitor and a  $3000\Omega$  resistor and gains half of its total charge in time  $t_1$ . RC circuit 2 consists of a 4V battery, a  $24\mu\text{F}$  capacitor and a  $1500\Omega$  resistor and gains half its total charge in time  $t_2$ . Select the correct statement.

- [A]  $t_1 < t_2$
- [B]  $t_1 = t_2$
- [C]  $t_1 > t_2$
- [D] There is not enough information provided to select one of the other answers.

(8) \_\_\_\_\_ **4.** A current loop is in a region of uniform magnetic field as illustrated. Select the correct statement.

- [A] The potential energy is at the minimum.
- [B] The potential energy is zero.
- [C] The potential energy is at the maximum.
- [D] The potential energy is infinite.

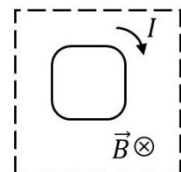

(8) \_\_\_\_\_ **5.** (Free) True or False, "Current students should not be forced to field these silly free questions. They can reach their potential by exercising their power to resist."

/40
-----

6. When an air-filled parallel plate capacitor is connected to a power supply the energy stored in the capacitor is  $U_0$ . The capacitor is kept connected to the supply while a dielectric slab with dielectric constant  $\kappa$  is inserted into and completely fills the space between the capacitor plates. This **increases** the energy stored in the capacitor by  $\Delta U$ .

(20) Determine the dielectric constant  $\kappa$  of the slab in terms of  $\Delta U$  and  $U_0$ ?

7. A rectangular wire made from a material with resistivity  $\rho = 5.00 \times 10^{-7} \Omega\text{-m}$  has sides of length 2.0 cm, 1.0 cm, and 4.0 cm along the  $x$ ,  $y$ , and  $z$  axes respectively. A potential difference of 2.0 mV is established across the wire so that the current is along the  $z$  axis.

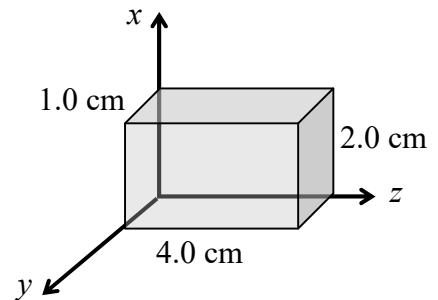

(20) Determine the magnitude of the current density in the wire.

8. Consider the illustrated circuit. The battery has an internal resistance  $r = 2\Omega$ . The other resistors have resistances  $R_1 = 8\Omega$ ,  $R_2 = 9\Omega$  and  $R_3 = 15\Omega$ .

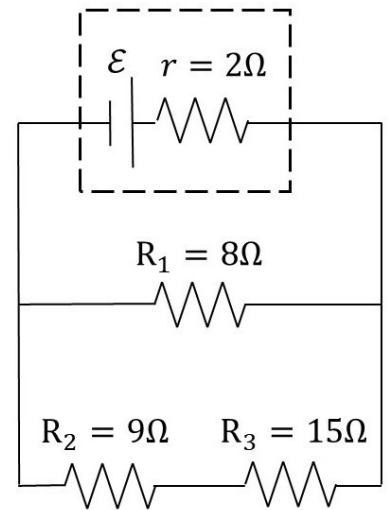

- (15) a. Determine  $R_E$  the equivalent resistance for the circuit, including the internal resistance of the battery.

$R_E =$
---------

- (15) b. The rate at which energy is dissipated in  $R_2$  is  $36W$ . Determine  $I_1$ , the current through  $R_1$ , and  $V_3$ , the potential across  $R_3$ .

$I_1 =$
$V_3 =$

- (10) c.  $R_1$  is made of a material with a resistivity temperature coefficient of  $0.005/^\circ C$ . Determine the final resistance of  $R_{1f}$  if it heats up by  $100^\circ C$ . Note that the initial resistance prior to heating was  $R_{1i} = 8\Omega$ .

$R_{1f} =$
------------

<b>/40</b>
------------

9. A circuit consists of a battery with an emf  $\mathcal{E}$  and an internal resistance of  $r$ , a resistance  $R$ , and a capacitance  $C$ , as shown. The capacitor is not initially charged. Give your answers **only in terms of  $\mathcal{E}$ ,  $r$ ,  $C$  and  $R$** .

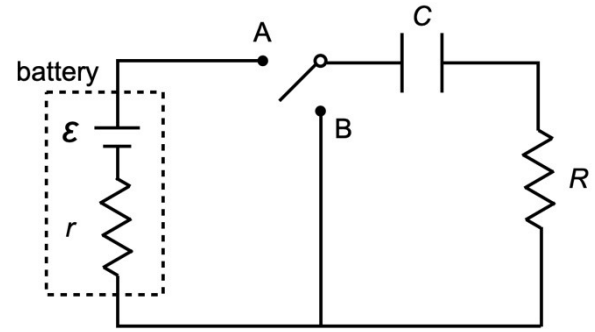

- (8) a. What is the initial current through the resistors immediately after the switch is set to position 'A'?

$$I =$$

- (12) b. How long does it take for the capacitor to be charged up to  $2/3$  of the final charge?

$$t =$$

The switch is set to position 'B' after the capacitor is charged for a long time.

- (8) c. What is the charge on the capacitor right after the switch is set to 'B'?

$$Q =$$

- (12) d. How long does it take for the power dissipated in  $R$  to be  $1/4$  of its initial value after the switch is set to position 'B'?

$$t =$$

$$/40$$

10. A single rectangular current loop carries a counter-clockwise current  $I_0$  in a region of uniform magnetic field  $\vec{B} = B_0 \hat{i}$ . One side of the loop has length  $2a$  and is parallel to the  $x$ -axis and another side has length  $a$  and is parallel to the  $y$ -axis.

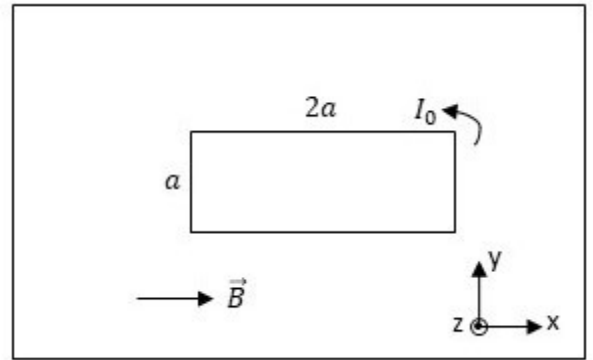

- (10) a. Determine the magnetic force (magnitude and direction) on the top side of the loop.

$$\vec{F}_{top} =$$

- (10) b. Determine the magnetic force (magnitude and direction) on the left side of the loop.

$$\vec{F}_{left} =$$

- (10) c. Determine the torque (magnitude and direction) on the loop.

$$\vec{\tau} =$$

- (10) d. Determine the potential energy of the loop.

$$U =$$

$$/40$$