

<b>Exam Total</b>    <b>/200</b>
--

**PHYS 2135 Exam II**  
April 2, 2019

Name: \_\_\_\_\_ Section: \_\_\_\_\_

For questions 1-5, select the best answer. For problems 6-11, solutions must begin with an Official Starting Equation, when appropriate. Work must be shown to receive credit. Calculators are not allowed.

- (8) \_\_\_\_\_ 1. You have a charged, isolated parallel plate capacitor. A material with dielectric constant  $\kappa$  is then inserted between its plates.
- [A] The capacitance increases and the stored energy decreases.
  - [B] The capacitance increases and the stored energy increases.
  - [C] The voltage between the plates decreases and the charge on the plates increases.
  - [D] The voltage between the plates increases and the charge on the plates decreases.

- (8) \_\_\_\_\_ 2. A potential difference is maintained across a cylindrical copper conductor. The resistance of the conductor can be increased by
- [A] increasing the potential difference across the conductor
  - [B] decreasing the radius of the conductor
  - [C] decreasing the length of the conductor
  - [D] increasing the current in the conductor.

- (8) \_\_\_\_\_ 3. A square loop is placed in a uniform magnetic field directed as shown in the diagram. The entire loop is in the magnetic field. There is a current  $I_0$  around the loop as shown. Which is true about the net force and net torque on the loop?
- [A] The net force is zero, but there is a net torque.
  - [B] There is a net force, but the net torque is zero.
  - [C] There is a net force and a net torque.
  - [D] The net force is zero and the net torque is zero.

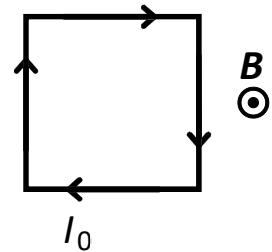

- (8) \_\_\_\_\_ 4. Between which two points in the circuit shown is the equivalent resistance the largest?
- [A] A and B
  - [B] A and C
  - [C] B and C

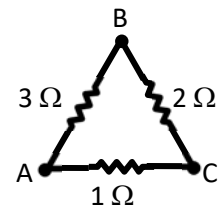

- (8) \_\_\_\_\_ 5 (Free). This problem is ...
- [A] too easy.
  - [B] just right.
  - [C] too hard.
  - [D] none of the above.

/40
-----

6. An air-filled parallel-plate capacitor consists of two square plates of edge length  $L$  and plate separation  $d$ . It is charged to an initial voltage  $V_0$ . Express your answers below in terms of  $L$ ,  $d$ ,  $V_0$ , and relevant constants.

(10) (a) Determine the capacitance **and** the charge of the capacitor.

(20) (b) After the **capacitor is disconnected** from the voltage source, a dielectric with dielectric constant  $\kappa = 4$  is inserted into the capacitor completely filling the space between the capacitor plates. Calculate the potential difference  $V$  between the two plates.



(10) (c) Calculate the capacitance of the capacitor if the same dielectric fills only half of the space between the capacitor plates (see figure). (Think of this capacitor as equivalent to two capacitors in parallel.)

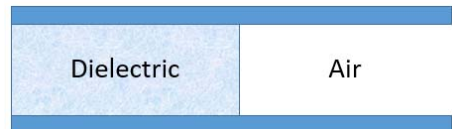

7. Your car has died and you need to restart it using an external battery having negligible internal resistance and an emf of  $\mathcal{E} = 10\text{V}$ . To connect the battery to the starter motor, you use two jumper cables whose resistance is negligibly small. The starter motor consists of three components having resistances  $R_1$ ,  $R_2$ , and  $R_3$ , whose total equivalent resistance  $R_T = 50\text{m}\Omega$ , as shown in the figure,

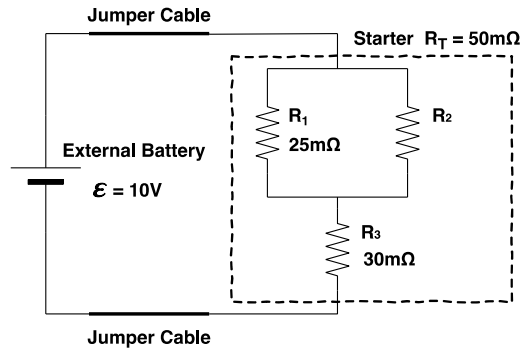

- (12) (a) Calculate  $R_2$ .
- (12) (b) Calculate the total electrical power drawn from the battery **and** the power dissipated in  $R_3$ .

8. Consider a hollow metal cylinder of length  $h$ , inner radius  $a$ , outer radius  $b$ , and resistivity  $\rho$ . The inner and outer surfaces of the cylinder are connected to an external circuit so that current flows radially outward from the inner surface to the outer surface.

- (12) (a) Compute the resistance of the conductor under these conditions. [Hint: solution may require integration.]

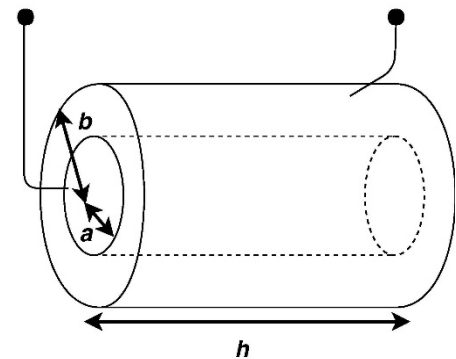

- (4) (b) Find a minimum length of the cylinder if the resistance needs to be equal to or smaller than  $R_0$ .

9. The circuit shown contains an uncharged capacitor with capacitance  $C$  and a resistor with resistance  $R$  which are in series with a battery of emf  $\mathcal{E}$ . (Start with an OSE and express all answers in terms of  $C$ ,  $R$  and  $\mathcal{E}$ )

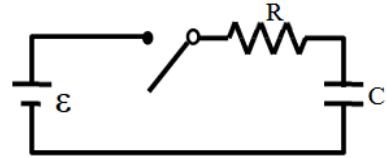

- (5) (a) When the switch is first closed, what is the current in the circuit?
- (5) (b) After the switch has been closed a long time, what is the charge on the capacitor?
- (10) (c) How long will it take for the current in the circuit to be  $\frac{1}{6}$  the initial value?

10. The circuit shown contains a capacitor with charge  $Q_0$  and resistor  $R$ . (Start with an OSE and express all answers in terms of  $Q_0$ ,  $R$  and  $C$ )

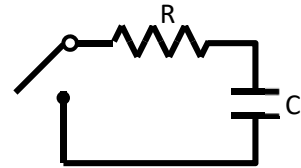

- (5) (a) When the switch is first closed, what is the voltage across the capacitor?
- (5) (b) When the switch is first closed, what is the current in the circuit?
- (10) (c) How long will it take for the voltage across the capacitor to become  $\frac{1}{3}$  the initial value?

11. A particle moving in the negative y-direction at a speed of  $v_0 = 6.0 \times 10^6 \text{ m/s}$  enters a uniform magnetic field that is horizontal and pointing along the positive x-axis.

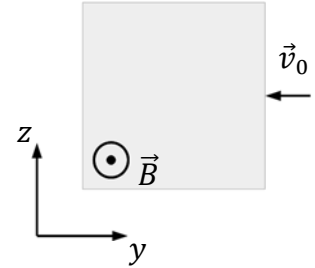

- (10) (a) The particle is deflected initially in the positive z-direction in the field. Is the charge of the particle **positive** or **negative**? [Circle the correct option.]
- (10) (b) If  $B = 0.25 \text{ T}$  and the charge-to-mass ratio ( $q/m$ ) of the particle is  $4.0 \times 10^7 \text{ C/kg}$ , what is the radius of the path?
- (10) (c) What is the time required by the particle to complete a circular path?
- (10) (d) What is the speed of the particle after it has moved in the field for  $1.0 \times 10^{-5} \text{ s}$ ?