

Physics 2135 Exam 2

October 21, 2014

Exam Total

/ 200

Printed Name: _____

Rec. Sec. Letter: _____

Five multiple choice questions, 8 points each. Choose the **best** or **most nearly correct** answer.

_____ 1. An air-filled parallel plate capacitor is connected across a potential difference V_0 and fully charged. The capacitor is then disconnected from the circuit. After that, a sheet of glass is inserted between the plates. Which of the following best describes the change that results?

- [A] The charge stored on the capacitor decreases.
- [B] The electric field between the plates increases.
- [C] The potential difference across the plates increases.
- [D] The electric energy stored in the capacitor decreases.

_____ 2. A wire segment carrying a current I consists of a semicircle of diameter D and two horizontal straight portions each of length L . The entire wire is in a region where there is a uniform magnetic field B as shown. What is the direction of the net magnetic force on the wire segment?

- [A] \uparrow
- [B] \otimes
- [C] \downarrow
- [D] \odot .

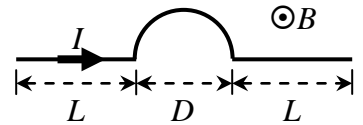

_____ 3. A negatively charged particle enters a region of constant magnetic field as shown. The **initial** deflection of the particle is

- [A] \uparrow
- [B] \otimes
- [C] \downarrow
- [D] \odot .

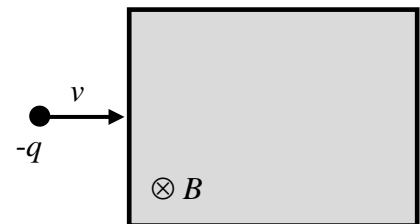

_____ 4. A circular current loop carrying $I = 3$ A has an area of $A = 200$ cm² and is oriented so that the plane of the loop is parallel to a constant magnetic field $B = 0.8$ T. The magnitude of the torque acting on the current loop is

- [A] 0
- [B] 0.048 N·m
- [C] 0.096 N·m
- [D] 480 N·m.

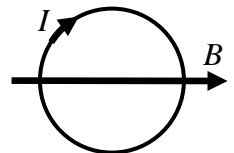

_____ 5. A cat is rubbed so that it acquires an electric charge and then dropped from a height of 5 feet in a region where Earth's magnetic field points away from north. As it falls, the cat will

- [A] rotate to the left.
- [B] rotate to the right.
- [C] emit sparks as it dissipates its excess charge.
- [D] do any or none of some or all of the above.

Note: no cats were damaged in the creation of this problem.

6. (20 points total) An appliance is connected across a 120 V source. When it is first turned on at 20 °C it dissipates a power of 1200 W. After several minutes, the appliance reaches its operating temperature of 370 °C. The temperature coefficient of resistivity for the primary resistance in the appliance is $4.0 \times 10^{-3} \text{ (}^\circ\text{C)}^{-1}$.

(a) (10 points) Calculate the initial current passing through the appliance at 20 °C.

(b) (10 points) Calculate the resistance of the appliance at 370 °C.

(c) (10 points) Calculate the power dissipated by the hot appliance at 370 °C.

(d) (10 points) Calculate the current passing through the hot appliance at 370 °C.

7. (40 points total) In the circuit shown $R_1 = 6\Omega$, $R_2 = 4\Omega$, $R_3 = 12\Omega$, $r = 1\Omega$, and $\varepsilon = 30V$.

(a) (10 points) Find the equivalent resistance of the entire circuit, including the internal resistance of the battery.

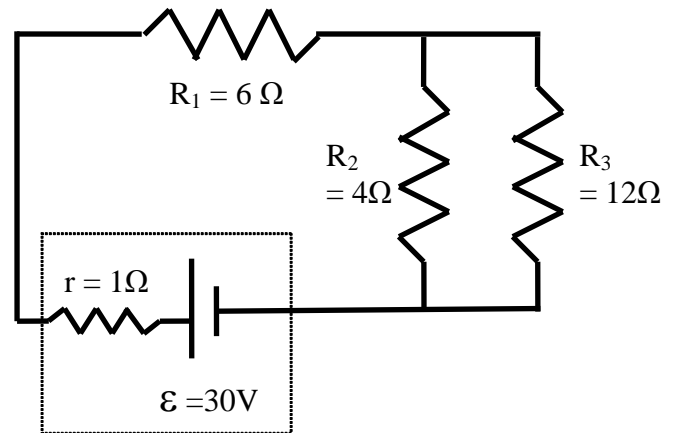

(b) (30 points) Find the voltage across each of the external resistors R_1 , R_2 , and R_3 , and the current flowing through each of the external resistors R_1 , R_2 , and R_3 .

8. (40 points total) The circuit in a camera flash unit contains a capacitor and a power supply that charges the capacitor to a voltage V_0 when the capacitor is fully charged.

(a) (10 points) If the voltage across the initially uncharged capacitor increases to $0.99 V_0$ in a time interval of 2 s, what is the time constant $\tau = RC$ of the charging circuit?

(b) (20 points) When you depress the shutter to take a picture, the fully-charged capacitor is connected across a flash filament of low resistance R . This allows the energy stored in the capacitor to quickly dissipate through the flash filament. Starting with appropriate OSEs derive an equation for the energy $U(t)$ stored in the discharging capacitor as a function of time. Express your answer in terms of V_0 , C , R , and t .

(c) (10 points) When the flash circuit is activated, the voltage across the capacitor decreases from its initial voltage to one-fourth of its initial value in a time interval of 1 ms. If $C = 180 \mu\text{F}$, find the total resistance R of the discharging flash circuit.

9. (20 points total) In a space station in orbit around the Earth, the astronauts decide to have a basketball game in their gym. They rotate the space station until the Earth's magnetic field \vec{B}_E is parallel to the gymnasium's floor, $\vec{B}_E = B_0 \hat{i}$. Their "ball" is a balloon which they rub on their shirts to give a uniform positive charge q . One astronaut launches the "ball" with a velocity $\vec{v} = v_{0x} \hat{i} + v_{0y} \hat{j} + v_{0z} \hat{k}$. Derive an expression for the force that the Earth's magnetic field exerts on the balloon. Express your answer in unit vector notation, using the parameters given in the statement of the problem.

10. (20 points total) The ratio of a particle's charge to its mass is an important parameter in the study of electrodynamics. Suppose a beam of electrons of speed v enters a region of uniform magnetic field B as shown in the diagram. The electrons are observed to follow a circular path of radius R . Begin with OSE's and derive an equation for the ratio e/m for an electron.

