

Physics 2135 Exam 1

February 14, 2017

Exam Total

/ 200

Printed Name: _____

Rec. Sec. Letter: _____

Five multiple choice questions, 8 points each. Choose the **best** or **most nearly correct** answer.

_____ 1. Two charges Q_1 and Q_2 are separated by a distance d . The Coulomb force between them has magnitude F . After the charges are pulled apart to a larger distance, the magnitude of the Coulomb force is now $F/4$. What is the new distance?

- [A] $4d$ [B] $2d$ [C] $16d$ [D] cannot tell without knowing Q_1 and Q_2

_____ 2. An electron is initially traveling horizontally with velocity v_0 in a region where there is a uniform electric field. The electric field deflects the electron down. What is the direction of the electric field?

- [A] up [B] down [C] right [D] left

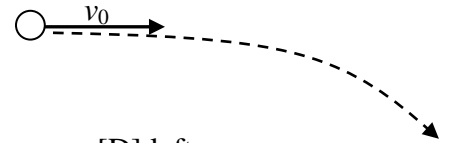

_____ 3. The electric potential in some region of space is given by $V = Ax^2y^2 - By$ where A and B are positive constants. The y -component of the electric field is:

- [A] $2Axy^2$ [B] $2Ax^2y - B$ [C] $-By$
[D] $-2Axy^2$ [E] $-2Ax^2y + B$

_____ 4. An electric dipole placed in a uniform electric field has minimum electric potential energy when \vec{p} is _____ and maximum magnitude torque when \vec{p} is _____.

- [A] parallel to \vec{E} , parallel to \vec{E} .
[B] parallel to \vec{E} , perpendicular to \vec{E} .
[C] perpendicular to \vec{E} , parallel to \vec{E} .
[D] perpendicular to \vec{E} , perpendicular to \vec{E} .

_____ 5. The capacitance of a parallel-plate capacitor can be increased by

- [A] decreasing the charge on each plate
[B] decreasing the area of each plate
[C] decreasing the spacing between the plates
[D] decreasing the potential difference across the plates.

_____/40 for page 1

6. (40 points total) A solid insulating sphere of radius a has a total charge Q distributed uniformly throughout the sphere and is surrounded by a spherical metal conducting shell of inner radius a and outer radius b that carries a net charge of $-3Q$.

- a) Use Gauss' Law to derive an expression for the magnitude of the electric field inside the insulating sphere for $0 < r < a$. (20 points)

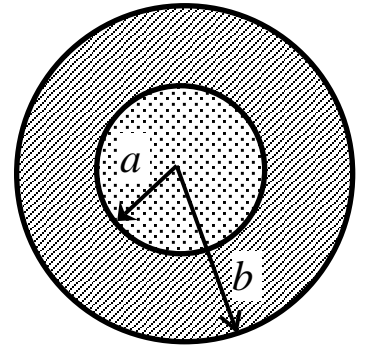

- b) What is the electric field for $a < r < b$? (5 points)

- c) Using Gauss' Law find the magnitude of the electric field for $r > b$. (10 points)

- d) Determine the charge on the outer surface of the spherical metal conducting shell. (5 points)

7. (40 points total) Three identical positive point charges Q sit on three of the corners of a rectangle with edges of length a and b as shown.

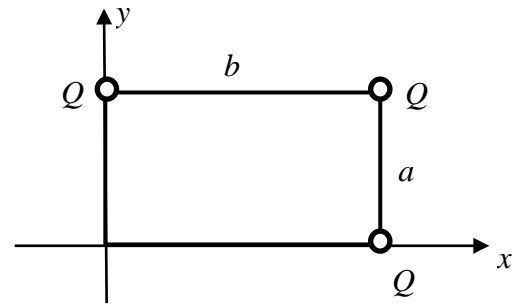

a) Determine the x and y components of the electric field at the origin due to these three charges. Express your answer in terms of Q , a , b , and Coulomb's constant k , all of which you should leave in symbolic form. (20 points)

b) Determine the electrical potential at the origin due to these three point charges, assuming that the potential is zero at a point infinitely far away. Express your answer in terms of Q , a , b , and Coulomb's constant k , all of which you should leave in symbolic form. (10 points)

c) A proton is now placed at the origin. Determine the **electrical force** exerted on the proton by the three charges. Express your answer in **unit vector notation** in terms of Q , a , b , Coulomb's constant k , and the fundamental electronic charge e , all of which you should leave in symbolic form. (10 points)

8. (40 points total) Positive electric charge $q_1 = +2Q$ and negative charges $q_2 = -3Q$, and $q_3 = -10Q$ are uniformly distributed, respectively, along three insulating rods bent into quarter circles as shown in the figure.

- a) Calculate the net electric potential at the origin due to the three bent charged rods. (20 points)

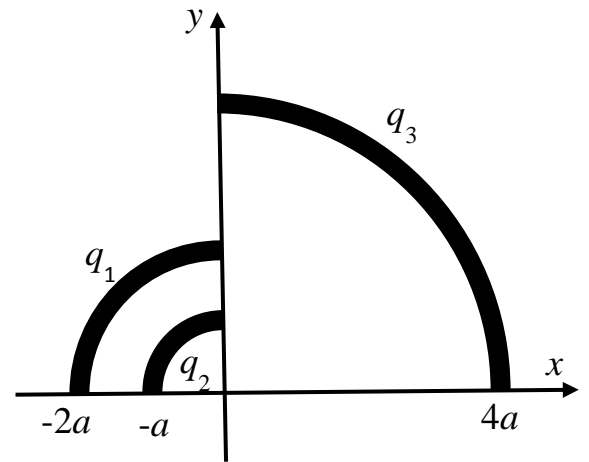

- b) A small ball of mass m and negative charge $-q$ is now slowly moved from infinity to the origin. How much work is done by the external agent that moves the charge? (10 points)

- c) The small ball of mass m and negative charge $-q$ is now released from rest at the origin. What is the maximum speed it reaches? (10 points)

9. (40 points total) In the figure, $C_1 = 4\mu\text{F}$, $C_2 = 8\mu\text{F}$, $C_3 = 4\mu\text{F}$, and $C_4 = 2\mu\text{F}$. The capacitor network is connected across an applied voltage V_{ab} . After the charges on the capacitors have reached their final values, the charge on C_3 is $Q_3 = 192\mu\text{C}$.

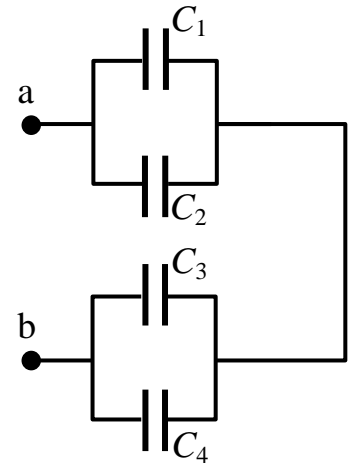

a) What is the equivalent capacitance of the system? (10 points)

b) What are Q_4 and V_4 ? (10 points)

c) What are Q_1 and V_1 ? (10 points)

d) What are Q_2 and V_2 ? (10 points)